



# User Manual

## GS2018PS2

16-Gigabit PoE Port + 2-Gigabit Port + 2-SFP Gigabit Port

# Content

|  |        |
|--|--------|
| 0 Foreword .....                               | - 1 -  |
| 0.1 Target Audience .....                      | - 1 -  |
| 0.2 Manual Convention .....                    | - 1 -  |
| 1 Management Software Specification .....      | - 2 -  |
| 2 Web Page Login .....                         | - 4 -  |
| 2.1 Log in the Network Management Client ..... | - 4 -  |
| 2.2 Constitution of Client Interface .....     | - 5 -  |
| 2.3 Navigation Tree on Web Interface .....     | - 5 -  |
| 3 System Configuration .....                   | - 13 - |
| 3.1 System Info .....                          | - 13 - |
| 3.2 Network Configuration .....                | - 13 - |
| 3.3 User Configuration .....                   | - 14 - |
| 3.4 Log Configuration .....                    | - 15 - |
| 3.5 Telnet Configuration .....                 | - 17 - |
| 3.6 HTTPS Configuration .....                  | - 17 - |
| 3.7 Diagnostics Test .....                     | - 18 - |
| 4 Port Configuration .....                     | - 20 - |
| 4.1 Physical Port .....                        | - 20 - |
| 4.2 Storm Policing .....                       | - 21 - |
| 4.3 Port Rate limiting .....                   | - 23 - |
| 4.4 Port Mirroring .....                       | - 24 - |
| 4.5 Link Aggregation .....                     | - 26 - |
| 4.5.1 About Link Aggregation .....             | - 26 - |
| 4.5.2 Add Static Link Aggregation .....        | - 27 - |
| 4.5.3 Add Dynamic Link Aggregation .....       | - 29 - |
| 4.6 Port Isolation .....                       | - 32 - |
| 4.7 Port Statistics .....                      | - 33 - |
| 5 PoE .....                                    | - 35 - |
| 5.1 PoE Port Setting .....                     | - 35 - |
| 5.2 POE Port Timer Setting .....               | - 36 - |
| 6 L2 Configuration .....                       | - 38 - |
| 6.1 VLAN Configuration .....                   | - 38 - |
| 6.2 MAC VLAN .....                             | - 44 - |
| 6.3 Protocol VLAN .....                        | - 47 - |
| 6.4 Voice VLAN .....                           | - 52 - |
| 6.5 MAC Configuration .....                    | - 57 - |
| 6.5.1 MAC Configuration .....                  | - 57 - |
| 6.6 MSTP Configuration .....                   | - 60 - |
| 6.6.1 Global Configuration .....               | - 61 - |
| 6.6.2 Instance Configuration .....             | - 62 - |

|  |         |
|--|---------|
| 6.6.3 Instance Port Configuration .....        | - 64 -  |
| 6.6.4 Port Configuration .....                 | - 65 -  |
| 6.7 IGMP Snooping Configuration .....          | - 70 -  |
| 6.7.1 IGMP Snooping Configuration .....        | - 70 -  |
| 6.7.2 Static Multicast .....                   | - 72 -  |
| 6.8 DHCP Snooping Configuration .....          | - 73 -  |
| 6.8.1 DHCP Snooping Global Configuration ..... | - 74 -  |
| 6.8.2 Static Binding .....                     | - 76 -  |
| 6.8.3 DHCP Snooping Port Configuration .....   | - 77 -  |
| 7 Network Security .....                       | - 82 -  |
| 7.1 DoS Attack Resistance .....                | - 82 -  |
| 7.1.1 Function Configuration .....             | - 82 -  |
| 7.1.2 Port Configuration .....                 | - 83 -  |
| 7.2 ACL Configuration .....                    | - 84 -  |
| 7.2.1 MAC ACL Configuration .....              | - 85 -  |
| 7.2.2 IPv4 ACL Configuration .....             | - 87 -  |
| 7.2.3 IPv6 ACL Configuration .....             | - 89 -  |
| 7.2.4 ACL Binding Configuration .....          | - 92 -  |
| 8 Advanced Configuration .....                 | - 93 -  |
| 8.1 QoS Configuration .....                    | - 95 -  |
| 8.1.1 Basic Configuration .....                | - 95 -  |
| 8.1.2 Queue Scheduling .....                   | - 96 -  |
| 8.1.3 CoS Mapping .....                        | - 97 -  |
| 8.1.4 DSCP Mapping .....                       | - 98 -  |
| 8.1.5 IP Priority Mapping .....                | - 99 -  |
| 8.2 LLDP Configuration .....                   | - 100 - |
| 8.2.1 LLDP Function Configuration .....        | - 101 - |
| 8.2.2 Port Configuration .....                 | - 102 - |
| 8.2.3 Neighbor Info .....                      | - 104 - |
| 8.3 SNMP Configuration .....                   | - 104 - |
| 8.3.1 View Configuration .....                 | - 105 - |
| 8.3.2 Group Configuration .....                | - 106 - |
| 8.3.3 Group Configuration .....                | - 107 - |
| 8.3.4 User Configuration .....                 | - 108 - |
| 8.3.5 Engine ID Configuration .....            | - 109 - |
| 8.3.6 Trap Configuration .....                 | - 110 - |
| 8.3.7 Notification Configuration .....         | - 111 - |
| 8.4 RMON Configuration .....                   | - 112 - |
| 8.4.1 Port Statistics .....                    | - 113 - |
| 8.4.2 History Configuration .....              | - 114 - |
| 8.4.3 Event Configuration .....                | - 115 - |
| 8.4.4 Alarm Configuration .....                | - 117 - |
| 8.5 DNS Configuration .....                    | - 119 - |
| 8.6 System Time .....                          | - 120 - |

|  |         |
|--|---------|
| 9 DHCP .....                                       | - 121 - |
| 9.1 DHCP Server brief introduction .....           | - 121 - |
| 9.2 IP address assignment of DHCP .....            | - 122 - |
| 9.2.1 IP address allocation strategy .....         | - 122 - |
| 9.2.2 Dynamic IP address acquisition process ..... | - 122 - |
| 9.3 DHCP global configuration .....                | - 124 - |
| 9.4 IP Pool Setting .....                          | - 125 - |
| 9.5 VLAN IF Address Group Setting .....            | - 125 - |
| 9.6 Client List .....                              | - 126 - |
| 9.7 Client Static Binding Table .....              | - 127 - |
| 10 System Maintenance .....                        | - 127 - |
| 10.1 Configuration Management .....                | - 127 - |
| 10.2 Configuration Saving .....                    | - 129 - |
| 10.4 Firmware Management .....                     | - 130 - |

# 0 Foreword

## 0.1 Target Audience

This manual is prepared for the installers and system administrators who are responsible for network installation, configuration and maintenance. It assumes that the user has understood all network communication and management protocols, as well as the technical terms, theoretical principles, practical skills, and expertise of devices, protocols and interfaces related to networking. Work experience in Graphical User Interface (GUI), Command-line Interface, Simple Network Management Protocol (SNMP) and Web Explorer is also required.

## 0.2 Manual Convention

The following approaches should prevail.

| GUI Convention  | Description  |
|---|--|
| Interpretation  | Describe operations and add necessary information.   |
|  Caution | Remind the user of cautions as improper operations will result in data loss or equipment damage. |

# 1 Management Software Specification

| 1. Layer 2 Functions |                  |  |                                  |
|----------------------|------------------|--|----------------------------------|
| 1.1                  | Port Management  | Enable/disable ports   | Available                        |
|                      |                  | Configure the speed, duplex and MTU  | Available                        |
|                      |                  | Flow control   | Available                        |
|                      |                  | Check the port information   | Available                        |
| 1.2                  | Port Mirroring   | Ingress/egress directions of port and aggregation group                              | Available                        |
| 1.3                  | Rate Limit       | Determine the bit rate by chips  | Available<br>Bit rate of 32 Kbps |
| 1.4                  | Port Isolation   | Configure port isolation   | Available                        |
| 1.5                  | Storm Policing   | Suppress the storms generated from unknown unicast, unknown multicast, and broadcast | Available                        |
| 1.6                  | Link Aggregation | Static link aggregation in manual mode   | Available                        |
|                      |                  | Dynamic aggregation in LACP mode   | Available                        |
| 1.7                  | VLAN             | Access   | Available                        |
|                      |                  | Trunk  | Available                        |
|                      |                  | Hybrid   | Available                        |
|                      |                  | QinQ and VLAN division based on port, protocol and MAC                               | Available                        |
|                      |                  | Dynamic VLAN registration of GVRP  | (128) Available                  |
|                      |                  | Voice VLAN (to be available)   | (16 OUI) Available               |
| 1.8                  | MAC              | Add or delete statically   | Available                        |
|                      |                  | Restrict the number of MAC address entries learned by an interface                   | Available                        |
|                      |                  | Set the dynamic aging time   | Available                        |
| 1.9                  | Spanning Tree    | 802.1d (STP)   | Available                        |
|                      |                  | 802.1w (RSTP)  | Available                        |
|                      |                  | 802.1s (MSTP)  | Available                        |

|                                |                     |  |           |
|--------------------------------|---------------------|--|-----------|
| 1.10                           | Multicast           | Add or delete statically;<br>IGMP Snooping   | Available |
|                                |                     | MLD Snooping   | Available |
|                                |                     | V1/2/3 dynamic multicast snooping  | Available |
| 1.11                           | DDM                 | SFP/SFP+DDM  | Available |
| <b>2. Extended Functions</b>   |                     |  |           |
| 2.1                            | ACL                 | Port numbers based on Source/Destination MAC, protocol type, Source/Destination IP, and L4 port. | Available |
| 2.2                            | QoS                 | Classified by 802.1p (CoS)   | Available |
|                                |                     | Classified by DSCP   | Available |
|                                |                     | Classified by Source/Destination IP and port   | Available |
|                                |                     | SP and WRR scheduling algorithms   | Available |
|                                |                     | Committed Access Rate (CAR)  | Available |
| 2.3                            | LLDP                | Link Layer Discovery Protocol (LLDP)   | Available |
| 2.4                            | User Configuration  | Add/delete a user  | Available |
| 2.5                            | Log                 | Login, operation, state, and event logs  | Available |
| 2.6                            | Attack Resistance   | DoS defense  | Available |
|                                |                     | Protect CPU and restrict message uploading rate  | Available |
|                                |                     | ARP binding (IP, MAC, Port)  | Available |
| 2.7                            | Authentication      | 802.1x port authentication   | Available |
|                                |                     | AAA  | Available |
| 2.8                            | Network Diagnostics | Ping, Telnet and traceroute  | Available |
| 2.9                            | System Management   | Unit resetting, configuration saving/restoring, upgrade, time setting, etc.                      | Available |
| <b>4. Management Functions</b> |                     |  |           |
| 4.1                            | CLI                 | Manage serial port command lines   | Available |
| 4.2                            | Telnet              | Remotely control Telnet  | Available |
| 4.3                            | SSH                 | Remotely control SSHv1/SSHv2   | Available |

|  |      |  |           |
|--|------|--|-----------|
| 4.4  | SNMP | SNMP v1/2/3                                      | Available |
|  |      | Trap: ColdStart, WarmStart, LinkDown, and LinkUp | Available |
| 4.5  | Web  | L2 setting, L2&3 discovery                       | Available |
| 4.6  | RMON | RMON v1  | Available |
| 5. Other Functions                                 |      |  |           |
| 5.1 DHCP Snooping and Option 82                    |      |  |           |
| 5.2 PoE configuration, scheduling management, etc. |      |  |           |
| 5.3 Dynamic ARP inspection                         |      |  |           |
| 5.4 TACACS and authentication                      |      |  |           |
| 5.5 DNS configuration                              |      |  |           |
| 5.6 Port security configuration                    |      |  |           |
| 5.7 MVR protocol                                   |      |  |           |
| 5.8 VCT  |      |  |           |
| 5.9 UDLD protocol                                  |      |  |           |

## 2 Web Page Login

### 2.1 Log in the Network Management Client

Type in the default switch address: `http://192.168.2.1` and press “Enter”.

Description:

Browser standards: superior to IE 9.0, Chrome 23.0 and Firefox 20.0

Keep the IP network segment of PC consistent with that of switch but differentiate the IP address as you log in. Set PC’s IP address of `192.168.2.x` and the subnet mask of `255.255.255.0` for the first login ( $1 < x \leq 254$ ).

A login window appears as follows. Type in the default username of “**admin**” and the password of “**admin**”. Click the “Log in” to see the switch system.

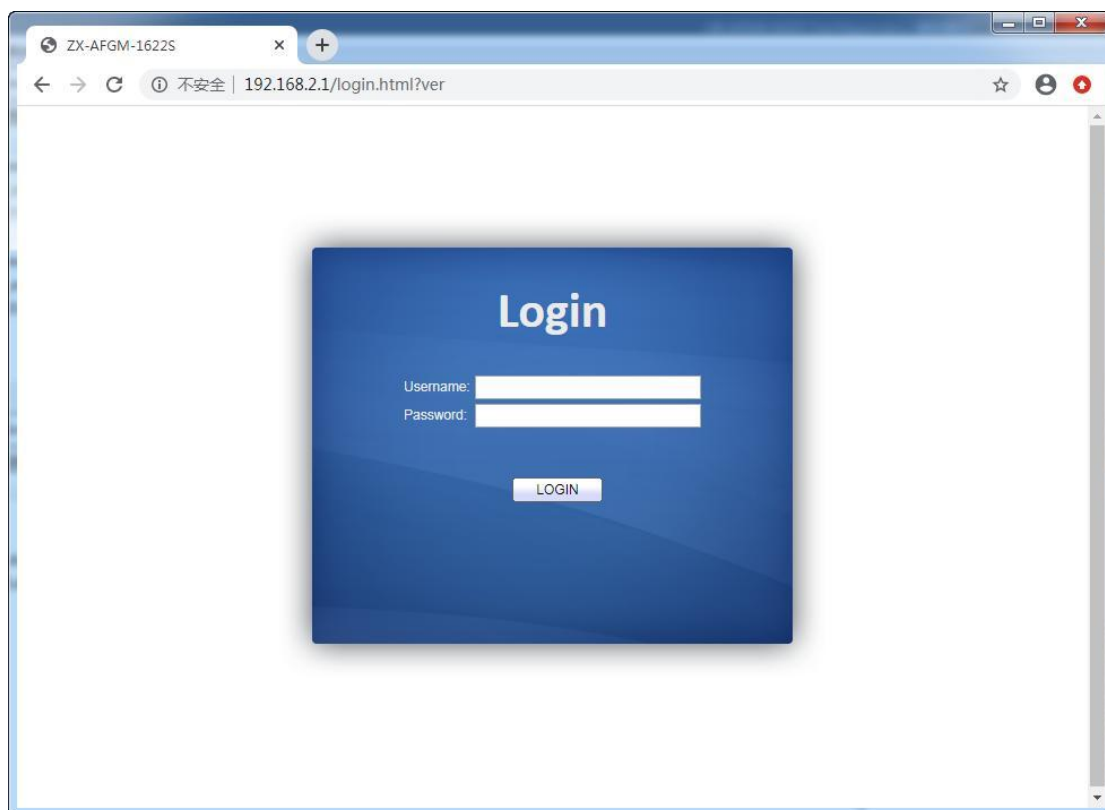

## 2.2 Constitution of Client Interface

The typical operation interface of Web network management system is as follows.

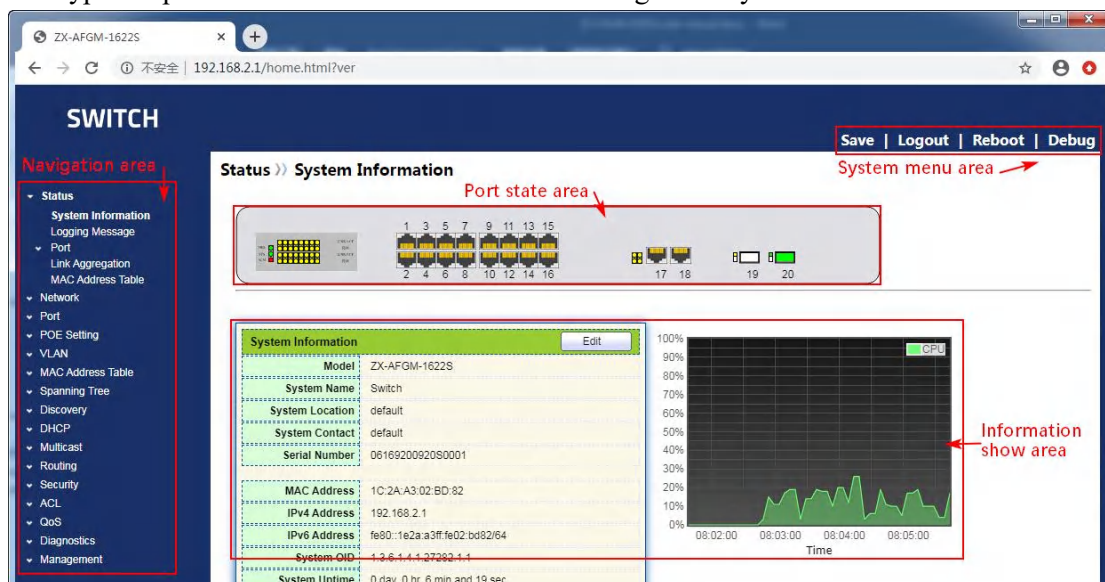

## 2.3 Navigation Tree on Web Interface

Menu items such as system state, network configuration, port, PoE setting, VLAN function, MAC address table, STP, topology discovery, multicast, security, ACL, QoS, device diagnostics and management are available on the web network management client. Each item contains submenus. Navigation tree is detailed as follows:

| Menu Items            | Submenus                  | Secondary Submenus                                  | Description  |  |
|-----------------------|---------------------------|---|--|--|
| System State          | System                    |   | Display the port state and product info                                      |  |
|                       | Log                       |   | Display the device running and operation logs                                |  |
|                       | Port                      | Port Statistics                                     |  | Display the detailed port statistics   |
|                       |                           | Port Fault Protection                               |  | Display the faults occurring to ports  |
|                       |                           | Bandwidth Utilization Rate                          |  | Display the bandwidth utilization per unit time of all ports                 |
|                       | Link Aggregation          |   | Display the aggregation group state and members                              |  |
| MAC Address Table     |                           | Display the MAC address table of the current device |  |  |
| Network Configuration | IP Address                |   | Configure and view the management IP of the current device                   |  |
|                       | DNS                       |   | Configure and view the DNS and server setting                                |  |
|                       | DNS Host                  |   | Configure and view the DNS Server and dynamic host mapping table             |  |
|                       | System Time               |   | Configure and view the current system time                                   |  |
| Port                  | Port Configuration        |   | Configure and view all ports   |  |
|                       | Port Fault Protection     |   | Configure and view the fault protection                                      |  |
|                       | Link Aggregation          | LAG Configuration                                   |  | Configure and view the port & strategy balancing algorithms contained in LAG |
|                       |                           | Port Configuration                                  |  | Configure and view the LAG   |
|                       |                           | LACP Configuration                                  |  | Check LACP system priority and port configuration                            |
|                       | EEE Configuration         |   | Configure and view the EEE state and info                                    |  |
|                       | Jumbo Frame Configuration |   | Configure and view the length of the max message forwarded by system         |  |
|                       | Port Security             |   | Configure and view the rate limiting of port security, as well as port state |  |
|                       | Port Isolation            |   | Configure and view the port isolation  |  |

|                                     |                             |                              |   |
|-------------------------------------|-----------------------------|------------------------------|---|
|                                     | Storm Policing              |                              | Configure and view the port storm policing                        |
|                                     | Mirroring                   |                              | Configure and view the port mirroring                             |
| PoE Configuration                   | PoE Port                    |                              | Configure and view the PoE port                                   |
|                                     | PoE Port Timing             |                              | Configure and view the timing switch of PoE port                  |
| VLAN Function                       | VLAN Configuration          | VLAN Creating                | Configure and view the VLAN info of the device                    |
|                                     |                             | VLAN Setting                 | Configure and view the VLAN configuration of all ports            |
|                                     |                             | Member Configuration         | Configure and view the port info of VLANs                         |
|                                     |                             | Port Configuration           | Configure and view the PVID and VLAN attributes of ports          |
|                                     | Voice VLAN                  | Function Configuration       | Configure and view the function switch and port state             |
|                                     |                             | Voice OUI Configuration      | Configure and view the OUI performance                            |
|                                     | Protocol VLAN Configuration | Protocol Group Configuration | Configure and view the protocol VLAN group                        |
|                                     |                             | Protocol Group Binding       | Configure and view the protocol VLAN port and group binding.      |
|                                     | MAC VLAN Configuration      | MAC Group Configuration      | Configure and view the MAC VLAN group                             |
|                                     |                             | MAC Group Binding            | Configure and view the MAC VLAN port and group binding            |
|                                     | GVRP                        | Function Configuration       | Configure and view the functional system and port state           |
|                                     |                             | Member List                  | Configure and view the VLANs learned and the port members         |
|                                     |                             | Message Statistics           | Configure and view the message statistics related to ports        |
|                                     | MAC Address Table           | Dynamic MAC Address Table    |   |
| Static MAC Address Table            |                             |                              | Configure and view the static MAC address tables of the device    |
| MAC Address Filtering Table         |                             |                              | Configure and view the MAC address tables to be filtered          |
| MAC Address Table for Port Security |                             |                              | Configure and view the MAC address table learned by port security |
| STP                                 | Function Configuration      |                              | Configure and view the STP state and attributes                   |

|                    |                             |                                    |  |
|--------------------|-----------------------------|------------------------------------|--|
|                    | Port Configuration          |                                    | Configure and view the port attributions of STP                                    |
|                    | Instance Configuration      |                                    | Configure and view the instance attributes of STPs                                 |
|                    | Instance Port Configuration |                                    | Configure and view the instances (incl. port info) of STPs                         |
|                    | Message Statistics          |                                    | Configure and view the STP message statistics of each port                         |
| Topology Discovery | LLDP                        | Function Configuration             | Configure and view the attributes related to LLDP                                  |
|                    |                             | Port Configuration                 | Configure and view the transmitting & receiving state of LLDP at each port         |
|                    |                             | MED Network Strategy Configuration | Configure and view the MED network strategy table entry                            |
|                    |                             | MED Port Configuration             | Configure and view the MED state at each port                                      |
|                    |                             | Message Preview                    | Configure and view the detailed LLDP messages at each port                         |
|                    |                             | Device Info                        | Configure and view the LLDP and LLDP-MED state                                     |
|                    |                             | Neighbor Info                      | Configure and view the LLDP neighbor info  |
|                    |                             | Message Statistics                 | Configure and view the transmitting & receiving state of LLDP message at each port |
| Multicast          | Basic Functions             | Function Configuration             | Configure and view the function configuration                                      |
|                    |                             | Static Multicast Configuration     | Configure and view the relevant static multicast info                              |
|                    |                             | Routed Port Configuration          | Configure and view the multicast routed port info                                  |
|                    |                             | Forwarding Port Configuration      | Configure and view the multicast forwarding port info                              |
|                    |                             | Port Limit                         | Configure and view the multicast limit at each port                                |
|                    |                             | Filtering Rule Configuration       | Configure and view the multicast addresses filtered                                |
|                    |                             | Filtering Rule Binding             | Configure and view the binding info related to filtering rule and ports            |
|                    | IGMP Snooping               | Function Configuration             | Configure and view the switch, version, etc.                                       |
|                    |                             | Querier                            | Configure and view the querier state   |

|                                  |              |                                     |  |  |
|----------------------------------|--------------|-------------------------------------|--|--|
|                                  |              | Configuration                       |  |  |
|                                  |              | Message Statistics                  | Configure and view the protocol messages                               |  |
|                                  | MLD Snooping | Function Configuration              | Configure and view the protocol, switch, etc.                          |  |
|                                  |              | Message Statistics                  | Configure and view the protocol messages                               |  |
|                                  | MVR          | Function Configuration              | Configure and view the attribute info such as switch                   |  |
|                                  |              | Port Configuration                  | Configure and view the state at each port                              |  |
|                                  |              | Group Address Configuration         | Configure and view the function, VLAN and group address                |  |
|                                  | Security     | RADIUS                              |  | Configure and view the info related to the servers |
|                                  |              | TACACS+                             |  | Configure and view the info related to the servers |
| AAA                              |              | Authentication Method Configuration | Configure and view the login authentication method                     |  |
|                                  |              | Login Authentication                | Configure and view the authentication methods of terminals             |  |
| Management Channel Configuration |              | VLAN Management                     | Configure and view the current VLAN management info                    |  |
|                                  |              | Service Management                  | Configure and view the service management mode and relevant attributes |  |
|                                  |              | ACL Management                      | Configure and view the ACL aiming at management channels               |  |
|                                  |              | ACE Management                      | Configure and view the ACE configuration of management channels        |  |
| Authentication Function          |              | Function Configuration              | Configure and view the authentication attributes                       |  |
|                                  |              | Port Configuration                  | Configure and view the authentication info at each port                |  |
|                                  |              | MAC Local Account                   | Configure and view the list of MAC local accounts                      |  |
|                                  |              | Web Local Account                   | Configure and view the list of Web local accounts                      |  |
|                                  |              | Session Info                        | Configure and view the info related to session authentication          |  |
| DoS Attack Resistance            |              | Function Configuration              | Configure and view the switch option                                   |  |

|     |                        |                                    |   |
|-----|------------------------|------------------------------------|---|
|     |                        | Port Configuration                 | Configure and view the switch option at ports                                   |
|     | Dynamic ARP Inspection | Function Configuration             | Configure and view the dynamic ARP inspection                                   |
|     |                        | Message Statistics                 | Configure and view the messages statistics in APR inspection state at each port |
|     | DHCP Snooping          | Function Configuration             | Configure and view the switch and state   |
|     |                        | Message Statistics                 | Configure and view the DHCP message statistics received by each port            |
|     |                        | Option 82 Function Configuration   | Configure and view the attributes related to Option 82                          |
|     |                        | Option 82 Circuit ID Configuration | Configure and view the Circuit ID of Option 82                                  |
|     | IP Source Guard        | Port Configuration                 | Configure and view the state at ports   |
|     |                        | IMPV Binding                       | Configure and view the binding tables of IP, MAC, Port and VLAN                 |
|     |                        | Database Storage                   | Configure and view the storage and info of the binding table entry              |
| ACL | MAC ACL Configuration  |                                    | Configure and view the MAC ACL rules  |
|     | MAC ACE Configuration  |                                    | Configure and view the MAC ACE table entries                                    |
|     | IPv4 ACL Configuration |                                    | Configure and view the IPv4 ACL rules   |
|     | IPv4 ACE Configuration |                                    | Configure and view the IPv4 ACE table entries                                   |
|     | IPv6 ACL Configuration |                                    | Configure and view the IPv6 ACL rules   |
|     | IPv6 ACE Configuration |                                    | Configure and view the IPv6 ACE table entries                                   |
|     | ACL Binding            |                                    | Configure and view the ACL rules and the port binding application               |
| QoS | Basic Function         | Function Configuration             | Configure and view the QoS switch and state                                     |
|     |                        | Queue Scheduling                   | Configure and view the algorithm of queue scheduling                            |
|     |                        | CoS Mapping                        | Configure and view the priority and local queue mapping table                   |
|     |                        | DSCP Mapping                       | Configure and view the priority and local queue mapping table                   |

|                    |                           |                             |  |
|--------------------|---------------------------|-----------------------------|--|
|                    |                           | IP Priority Mapping         | Configure and view the priority and local queue mapping table            |
|                    | Bandwidth Rate Limiting   | Rate Limiting               | Configure and view the configuration of port rate limiting               |
|                    |                           | Egress Queue Rate Limiting  | Configure and view the rate limiting configuration based on egress queue |
| Device Diagnostics | Log Function              | Function Configuration      | Configure and view the switch and state                                  |
|                    |                           | Remote Server Configuration | Configure and view the address of remote servers                         |
|                    | Ping                      |                             | Network diagnostics by Ping  |
|                    | Traceroute                |                             | Network diagnostics by traceroute  |
|                    | Electrical Interface Test |                             | Electrical interface link diagnostics by VCT                             |
|                    | Optical Module            |                             | Check the SFP module at optical interfaces                               |
|                    | UDLD Protocol             | Function Configuration      | Configure and view the switch and state                                  |
|                    |                           | Neighbor Info               | Configure and view the neighbor state                                    |
| Device Management  | User Configuration        |                             | Configure and view the user info   |
|                    | Firmware Management       | Upgrade/Backups             | Update software  |
|                    | Configuration Management  | Upgrade/Backups             | Update configuration files   |
|                    |                           | Configuration Saving        | Save the configuration files supporting device running                   |
|                    | SNMP Configuration        | View Configuration          | Configure and view the SNMP function view table entry                    |
|                    |                           | Group Configuration         | Configure and view the SNMP group  |
|                    |                           | Community Configuration     | Configure and view the SNMP Community                                    |
|                    |                           | User Configuration          | Configure and view the SNMP user attributes                              |
|                    |                           | Engine ID Configuration     | Configure and view the SNMP and remote Engine IDs                        |
|                    |                           | Trap Configuration          | Configure and view the SNMP Trap switch and state                        |
|                    |                           | Notification Configuration  | Configure and view the SNMP Notification server state                    |
|                    | RMON Configuration        | Message Statistics          | Configure and view the message statistics history of all ports           |
|                    |                           | History                     | Configure and view the history record                                    |

|  |  |                     |                                    |
|--|--|---------------------|------------------------------------|
|  |  | Configuration       | state                              |
|  |  | Event Configuration | Configure and view the event state |
|  |  | Alarm Configuration | Configure and view the alarm state |

# 3 System Configuration

## 3.1 System Info

According to the switch connected, web network management panel directly displays the port and product info, incl.: number of ports, port states, product info, device states, function on-off states, etc.

Instructions:

1. Click the “System Configuration > System Info” in the navigation tree as follows:

The screenshot shows a network management interface. At the top, there is a port status bar with 20 ports numbered 1 to 20. Below this, the 'System Information' panel is displayed, containing the following data:

| System Information |                               |
|--------------------|-------------------------------|
| Model              | ZX-AFGM-1622S                 |
| System Name        | Switch                        |
| System Location    | default                       |
| System Contact     | default                       |
| Serial Number      | 06169200920S0001              |
| MAC Address        | 1C:2A:A3:02:BD:82             |
| IPv4 Address       | 192.168.2.1                   |
| IPv6 Address       | fe80::1e2a:a3ff:fe02:bd82/64  |
| System OID         | 1.3.6.1.4.1.27282.1.1         |
| System Uptime      | 0 day, 0 hr, 6 min and 19 sec |
| Current Time       | 2020-01-01 08:05:52 UTC+8     |
| Loader Version     | 3.2.0.30                      |
| Loader Date        | Oct 16 2020 - 16:15:44        |
| Firmware Version   | 1.0.0.23                      |
| Firmware Date      | Oct 16 2020 - 16:39:26        |
| Telnet             | Disabled                      |
| SSH                | Disabled                      |
| HTTP               | Enabled                       |
| HTTPS              | Disabled                      |
| SNMP               | Disabled                      |

To the right of the system information panel are two performance graphs. The top graph is labeled 'CPU' and shows CPU usage percentage over time from 08:02:00 to 08:05:00. The usage fluctuates between approximately 10% and 30%. The bottom graph is labeled 'MEM' and shows memory usage percentage over the same time period. The usage starts at 0%, jumps to about 65% at 08:03:00, and remains stable around 65% until 08:05:00.

Description:

Mouseover a port to check the port No., type, rate and state.

“Modify” the “System Name”, “Location” and “Contact” in the product info. “Apply” and finish.

## 3.2 Network Configuration

Change the management IP address on web interface.

Instructions:

1. Click the “Network Configuration > IP Address Setting” in the navigation bar to discover IPv4 address of 192.168.2.1/24 by default as follows:
2. Repeat this step, select the “Static” address type, enter the IPv4 address of 192.168.2.1, the subnet mask of 255.255.255.0, and the network management of 192.168.2.254. “Apply” and finish.

| IPv4 Address         |  |
|----------------------|--|
| Address Type         | <input checked="" type="radio"/> Static<br><input type="radio"/> Dynamic |
| IP Address           | 192.168.2.1  |
| Subnet Mask          | 255.255.255.0  |
| Default Gateway      | 192.168.2.254  |
| Sub IPv4 Address     |  |
| Enabled              | <input type="checkbox"/> Enable  |
| IP Address           | 0.0.0.0  |
| Subnet Mask          | 0.0.0.0  |
| IPv6 Address         |  |
| Auto Configuration   | <input checked="" type="checkbox"/> Enable                               |
| DHCPv6 Client        | <input type="checkbox"/> Enable  |
| IPv6 Address         |  |
| Prefix Length        | 0 (0 - 128)  |
| IPv6 Gateway         |  |
| Operational Status   |  |
| IPv4 Address         | 192.168.2.1  |
| IPv4 Default Gateway | 192.168.2.254  |
| Sub IPv4 Address     | 0.0.0.0  |
| IPv6 Address         | ::   |
| IPv6 Gateway         | ::   |
| Link Local Address   | fe80::1e2a:a3ff:fe00:24/64   |

### 3.3 User Configuration

Users can check and modify the current username, password and authority of the switch.

Instructions:

1. Click the “Device Management > User Configuration” in the navigation bar to discover the username of “admin” and the authority of “administrator” by default as follows:

**User Account**

Showing All entries      Showing 1 to 1 of 1 entries     

| <input type="checkbox"/> | Username | Privilege |
|--------------------------|----------|-----------|
| <input type="checkbox"/> | admin    | Admin     |

 
  
  
  
  
1  
  

2. “Add” a new user account and “Modify” the selected user attribute as follows:

**Add User Account**

|                         |  |
|-------------------------|--|
| <b>Username</b>         | <input type="text"/>   |
| <b>Password</b>         | <input type="text"/>   |
| <b>Confirm Password</b> | <input type="text"/>   |
| <b>Privilege</b>        | <input checked="" type="radio"/> Admin<br><input type="radio"/> User |

**Edit User Account**

|                         |  |
|-------------------------|--|
| <b>Username</b>         | admin  |
| <b>Password</b>         | <input type="text"/>   |
| <b>Confirm Password</b> | <input type="text"/>   |
| <b>Privilege</b>        | <input checked="" type="radio"/> Admin<br><input type="radio"/> User |

### 3.4 Log Configuration

It configures log switch, info integration, aging time and configuration level. It also uploads the switch’s work logs to the TFTP Server.

Instructions:

1. Click the “Device Diagnostics > Log Function > Function Configuration” in the navigation bar to switch logs on/off, select the egress terminal, configure the severity level, etc. as follows:

|                         |   |
|-------------------------|---|
| <b>State</b>            | <input checked="" type="checkbox"/> Enable  |
| <b>Aggregation</b>      | <input checked="" type="checkbox"/> Enable  |
| <b>Aging Time</b>       | <input type="text" value="300"/> Sec (15 - 3600, default 300)                                   |
| <b>Console Logging</b>  |   |
| <b>State</b>            | <input checked="" type="checkbox"/> Enable  |
| <b>Minimum Severity</b> | <input type="text" value="Notice"/><br>Note: Emergency, Alert, Critical, Error, Warning, Notice |
| <b>RAM Logging</b>      |   |
| <b>State</b>            | <input checked="" type="checkbox"/> Enable  |
| <b>Minimum Severity</b> | <input type="text" value="Notice"/><br>Note: Emergency, Alert, Critical, Error, Warning, Notice |
| <b>Flash Logging</b>    |   |
| <b>State</b>            | <input type="checkbox"/> Enable   |
| <b>Minimum Severity</b> | <input type="text" value="Notice"/><br>Note: Emergency, Alert, Critical, Error, Warning, Notice |

- Click the “Device Diagnostics > Log Function > Remote Server Configuration” in the navigation bar to add and view the server configuration as follows:

**Remote Server Table**

| <input type="checkbox"/> | Entry | Server Address | Server Port | Facility | Minimum Severity |
|--------------------------|-------|----------------|-------------|----------|------------------|
| 0 results found.         |       |                |             |          |                  |

- “Add” a new remote log server and “Modify” the selected configuration. “Apply” and finish as follows:

### Add Remote Server

|   |   |                          |
|---|---|--------------------------|
| <b>Address Type</b>   | <input checked="" type="radio"/> Hostname<br><input type="radio"/> IPv4<br><input type="radio"/> IPv6 |                          |
| <b>Server Address</b>   | <input type="text"/>  |                          |
| <b>Server Port</b>  | <input type="text" value="514"/>  | (1 - 65535, default 514) |
| <b>Facility</b>   | Local 7 ▾   |                          |
| <b>Minimum Severity</b>   | Notice ▾  |                          |
| Note: Emergency, Alert, Critical, Error, Warning, Notice                  |   |                          |
| <input type="button" value="Apply"/> <input type="button" value="Close"/> |   |                          |

## 3.5 Telnet Configuration

Users can enable or disable the Telnet login option on web interface.

Instructions:

1. Click the “Security > Management Channel Configuration > Service Management” in the navigation bar to enable or disable the service by checking the “Telnet” tag. “Apply” and finish as follows:

| Management Service |                                     |                             |
|--------------------|-------------------------------------|-----------------------------|
| <b>Telnet</b>      | <input checked="" type="checkbox"/> | Enable                      |
| <b>SSH</b>         | <input type="checkbox"/>            | Enable                      |
| <b>HTTP</b>        | <input checked="" type="checkbox"/> | Enable                      |
| <b>HTTPS</b>       | <input type="checkbox"/>            | Enable                      |
| <b>SNMP</b>        | <input type="checkbox"/>            | Enable                      |
| Session Timeout    |                                     |                             |
| <b>Console</b>     | <input type="text" value="10"/>     | Min (0 - 65535, default 10) |
| <b>Telnet</b>      | <input type="text" value="10"/>     | Min (0 - 65535, default 10) |
| <b>SSH</b>         | <input type="text" value="10"/>     | Min (0 - 65535, default 10) |
| <b>HTTP</b>        | <input type="text" value="10"/>     | Min (0 - 65535, default 10) |
| <b>HTTPS</b>       | <input type="text" value="10"/>     | Min (0 - 65535, default 10) |

## 3.6 HTTPS Configuration

Users can enable or disable the HTTP & HTTPS login options on web interface.

Instructions:

1. Click the “Security > Management Channel Configuration > Service Management” in the navigation bar to enable or disable the services by checking the “HTTP” and “HTTPS” tags. “Apply” and finish as follows:

| Management Service |  |
|--------------------|--|
| Telnet             | <input type="checkbox"/> Enable            |
| SSH                | <input type="checkbox"/> Enable            |
| HTTP               | <input checked="" type="checkbox"/> Enable |
| HTTPS              | <input checked="" type="checkbox"/> Enable |
| SNMP               | <input type="checkbox"/> Enable            |

| Session Timeout |   |
|-----------------|---|
| Console         | 10 <small>Min (0 - 65535, default 10)</small> |
| Telnet          | 10 <small>Min (0 - 65535, default 10)</small> |
| SSH             | 10 <small>Min (0 - 65535, default 10)</small> |
| HTTP            | 10 <small>Min (0 - 65535, default 10)</small> |
| HTTPS           | 10 <small>Min (0 - 65535, default 10)</small> |

### 3.7 Diagnostics Test

Ping command checks the availability of specified IP addresses and host names and transmits statistics accordingly.

Instructions:

1. Click the “Device Diagnostics > Ping” in the navigation bar to enter a host name or an IP address, as well as the number of tests as follows:

|                |   |
|----------------|---|
| Address Type   | <input type="radio"/> Hostname<br><input checked="" type="radio"/> IPv4<br><input type="radio"/> IPv6 |
| Server Address | 192.168.1.111   |
| Count          | 4 <small>(1 - 65535)</small>  |

2. Click the “Ping” to accept the packet-transmitting test from system to verify address validity, and output the result as follows:

## Ping Result

| Packet Status   |          |
|-----------------|----------|
| Status          | Success. |
| Transmit Packet | 4        |
| Receive Packet  | 4        |
| Packet Lost     | 0 %      |
| Round Trip Time |          |
| Min             | 0 ms     |
| Max             | 0 ms     |
| Average         | 0 ms     |

Traceroute measures the duration from transmitting a small packet to receiving it back from the target device.

Instructions:

1. Click the “Device Diagnostics > Traceroute” in the navigation bar to enter a host name or IP address to define the message existence time as follows:

|                |  |
|----------------|--|
| Address Type   | <input type="radio"/> Hostname<br><input checked="" type="radio"/> IPv4                        |
| Server Address | 192.168.1.122  |
| Time to Live   | <input type="checkbox"/> User Defined<br><input type="text" value="30"/> (2 - 255, default 30) |

2. “Apply” to test and output the result as follows:

## Traceroute Result

```

traceroute to 192.168.1.122 (192.168.1.122), 30 hops max, 38 byte packets
1 192.168.1.122 (192.168.1.122) 0.000 ms 0.000 ms 0.000 ms
  
```

Electrical interface test evaluates the ingress cable state and locates the faults (about 5 m by error) according to the reflected voltage strength

Instructions:

1. Click the “Device Diagnostics > Electrical Interface Test” in the navigation bar to select a port for test as follows:

2. Click the “Copper Test” and output the result as follows:

#### Copper Test Result

| Cable Status |            |
|--------------|------------|
| Port         | GE1        |
| Result       | Open Cable |
| Length       | 2.92 M     |

## 4 Port Configuration

### 4.1 Physical Port

Interfaces should be identified so that users can inquire and configure Ethernet interfaces as they want.

Instructions:

1. Click the “Port > Port Configuration” in the navigation bar:

#### Port Setting Table

| Entry                    | Port | Type | Description  | State   | Link Status | Speed        | Duplex      | Flow Control   |
|--------------------------|------|------|--------------|---------|-------------|--------------|-------------|----------------|
| <input type="checkbox"/> | 1    | GE1  | 1000M Copper | Enabled | Down        | Auto         | Auto        | Disabled       |
| <input type="checkbox"/> | 2    | GE2  | 1000M Copper | Enabled | Down        | Auto         | Auto        | Disabled       |
| <input type="checkbox"/> | 3    | GE3  | 1000M Copper | Enabled | Down        | Auto         | Auto        | Disabled       |
| <input type="checkbox"/> | 4    | GE4  | 1000M Copper | Enabled | Up          | Auto (1000M) | Auto (Full) | Disabled (Off) |
| <input type="checkbox"/> | 5    | GE5  | 1000M Copper | Enabled | Down        | Auto         | Auto        | Disabled       |
| <input type="checkbox"/> | 6    | GE6  | 1000M Copper | Enabled | Down        | Auto         | Auto        | Disabled       |
| <input type="checkbox"/> | 7    | GE7  | 1000M Copper | Enabled | Down        | Auto         | Auto        | Disabled       |
| <input type="checkbox"/> | 8    | GE8  | 1000M Copper | Enabled | Down        | Auto         | Auto        | Disabled       |
| <input type="checkbox"/> | 9    | GE9  | 1000M Copper | Enabled | Down        | Auto         | Auto        | Disabled       |
| <input type="checkbox"/> | 10   | GE10 | 1000M Copper | Enabled | Up          | Auto (100M)  | Auto (Full) | Disabled (Off) |

2. Select the port(s) to be configured, and “Modify” as follows:

### Edit Port Setting

|                     |  |
|---------------------|--|
| <b>Port</b>         | GE3-GE5  |
| <b>Description</b>  | <input type="text"/>   |
| <b>State</b>        | <input checked="" type="checkbox"/> Enable   |
| <b>Speed</b>        | <input checked="" type="radio"/> Auto <input type="radio"/> 10M<br><input type="radio"/> Auto - 10M <input type="radio"/> 100M<br><input type="radio"/> Auto - 100M <input type="radio"/> 1000M<br><input type="radio"/> Auto - 1000M <input type="radio"/> 10G<br><input type="radio"/> Auto - 10M/100M |
| <b>Duplex</b>       | <input checked="" type="radio"/> Auto<br><input type="radio"/> Full<br><input type="radio"/> Half  |
| <b>Flow Control</b> | <input type="radio"/> Auto<br><input type="radio"/> Enable<br><input checked="" type="radio"/> Disable   |

Configuration items are as follows.

| Configuration Items | Description  |
|---------------------|--|
| Interpretation      | Users can identify the specified ports by interpreting them as required.   |
| State               | Users can enable or disable the ports as required.   |
| Rate                | Configurable auto negotiation with mandatory 10 Mb, 100 Mb and 1,000 Mb states. Interface rates including 10 Mbit/s, 100 Mbit/s and 1,000 Mbit/s are available to Ethernet electrical interfaces and are optional as required.   |
| Duplex              | Configurable auto negotiation with full or half duplexes.  |
| Flow Control        | After it is enabled on both local network and opposite network devices, the local one will notify the other to stop transmitting messages in the presence of network congestion. The opposite one will execute the command temporarily to ensure zero message loss.<br>Disable-Disabled reception and transmission of PAUSE frame;<br>Enable-Enabled reception and transmission of PAUSE frame;<br>Auto negotiation-Negotiate PAUSE frame with opposite network devices automatically. |

## 4.2 Storm Policing

Storm policing principles

Storms generated via broadcast, unknown multicast and unicast messages are prevented as follows. These messages will be suppressed subject to packet rates respectively. The average rate of the messages received by monitoring interfaces will be compared with the max threshold configured during an inspection interval. Configured storm policing will be performed at this interface if the average rate exceeds the max threshold.

When a L2 Ethernet interface receives the broadcast, unknown multicast or unicast messages, the device will forward them to other L2 interfaces in a same VLAN (Virtual Local Area Network) if the egress interface cannot be recognized according to destination MAC addresses. As a result, broadcast storm may occur to degrade device operation performance.

Three kinds of message flow can be controlled by storm policing characteristics to stay away from broadcast storms.

Instructions:

1. Click the “Port > Storm Policing” in the navigation bar to configure the attributes related to storm policing such as mode as follows:

Mode

Packet / Sec

Kbits / Sec

IFG

Exclude

Include

Apply

2. Select the appropriate port and “Modify” it by configuring the policing rates of broadcast, unknown multicast and unicast storms at each port.

Port Setting Table

| Entry                    | Port | State | Broadcast |             | Unknown Multicast |             | Unknown Unicast |             | Action |      |
|--------------------------|------|-------|-----------|-------------|-------------------|-------------|-----------------|-------------|--------|------|
|                          |      |       | State     | Rate (Kbps) | State             | Rate (Kbps) | State           | Rate (Kbps) |        |      |
| <input type="checkbox"/> | 1    | GE1   | Disabled  | Disabled    | 10000             | Disabled    | 10000           | Disabled    | 10000  | Drop |
| <input type="checkbox"/> | 2    | GE2   | Disabled  | Disabled    | 10000             | Disabled    | 10000           | Disabled    | 10000  | Drop |
| <input type="checkbox"/> | 3    | GE3   | Disabled  | Disabled    | 10000             | Disabled    | 10000           | Disabled    | 10000  | Drop |
| <input type="checkbox"/> | 4    | GE4   | Disabled  | Disabled    | 10000             | Disabled    | 10000           | Disabled    | 10000  | Drop |
| <input type="checkbox"/> | 5    | GE5   | Disabled  | Disabled    | 10000             | Disabled    | 10000           | Disabled    | 10000  | Drop |
| <input type="checkbox"/> | 6    | GE6   | Disabled  | Disabled    | 10000             | Disabled    | 10000           | Disabled    | 10000  | Drop |
| <input type="checkbox"/> | 7    | GE7   | Disabled  | Disabled    | 10000             | Disabled    | 10000           | Disabled    | 10000  | Drop |
| <input type="checkbox"/> | 8    | GE8   | Disabled  | Disabled    | 10000             | Disabled    | 10000           | Disabled    | 10000  | Drop |

3. Configure info such as storm switch and rate, “Apply” and finish as follows:

### Edit Port Setting

|                   |   |
|-------------------|---|
| Port              | GE3-GE5   |
| State             | <input checked="" type="checkbox"/> Enable  |
| Broadcast         | <input checked="" type="checkbox"/> Enable<br><input type="text" value="10000"/> Kbps (16 - 1000000, default 10000) |
| Unknown Multicast | <input checked="" type="checkbox"/> Enable<br><input type="text" value="10000"/> Kbps (16 - 1000000, default 10000) |
| Unknown Unicast   | <input checked="" type="checkbox"/> Enable<br><input type="text" value="10000"/> Kbps (16 - 1000000, default 10000) |
| Action            | <input type="radio"/> Drop<br><input type="radio"/> Shutdown  |

## 4.3 Port Rate limiting

It refers to the rate restriction on transmitting and receiving data at physical interfaces.

Background

Restrict the rate limiting at the egress before transmitting flow, thus controlling all outgoing message flow;

Restrict the rate limiting at the ingress before receiving flow, thus controlling all incoming message flow;

Instructions:

1. Click the “QoS > Bandwidth Rate Limiting > Port Rate Limiting” in the navigation bar to choose a rate-limiting port and check the current configuration as follows:

### Ingress / Egress Port Table

| Entry                    | Port | Ingress |             | Egress |             |
|--------------------------|------|---------|-------------|--------|-------------|
|                          |      | State   | Rate (Kbps) | State  | Rate (Kbps) |
| <input type="checkbox"/> | 1    | GE1     | Disabled    |        | Disabled    |
| <input type="checkbox"/> | 2    | GE2     | Disabled    |        | Disabled    |
| <input type="checkbox"/> | 3    | GE3     | Disabled    |        | Disabled    |
| <input type="checkbox"/> | 4    | GE4     | Disabled    |        | Disabled    |
| <input type="checkbox"/> | 5    | GE5     | Disabled    |        | Disabled    |
| <input type="checkbox"/> | 6    | GE6     | Disabled    |        | Disabled    |
| <input type="checkbox"/> | 7    | GE7     | Disabled    |        | Disabled    |
| <input type="checkbox"/> | 8    | GE8     | Disabled    |        | Disabled    |

- Select the port (s) for rate limiting, “Modify” it at the bottom to switch the function and specify the rate. “Apply” and finish as follows:

#### Edit Ingress / Egress Port

|                |  |                     |
|----------------|--|---------------------|
| <b>Port</b>    | GE3-GE5                                    |                     |
| <b>Ingress</b> | <input checked="" type="checkbox"/> Enable |                     |
|                | <input type="text" value="1000000"/>       | Kbps (16 - 1000000) |
| <b>Egress</b>  | <input checked="" type="checkbox"/> Enable |                     |
|                | <input type="text" value="1000000"/>       | Kbps (16 - 1000000) |

#### Configuration parameters

| Configuration Items |         | Description                           |
|---------------------|---------|---------------------------------------|
| Ingress             | Enabled | Rate limiting switch                  |
|                     | Rate    | Rate ranges from 16 to 1,000,000 Kbps |
| Egress              | Enabled | Rate limiting switch                  |
|                     | Rate    | Rate ranges from 16 to 1,000,000 Kbps |

## 4.4 Port Mirroring

Port Mirroring copies the message of a specified switch port to the destination port. The copied port is the Source Port, and the copying port is the Destination Port. Destination Port accesses to data inspection devices so that users can analyze the messages received to monitor network and troubleshoot as follows:

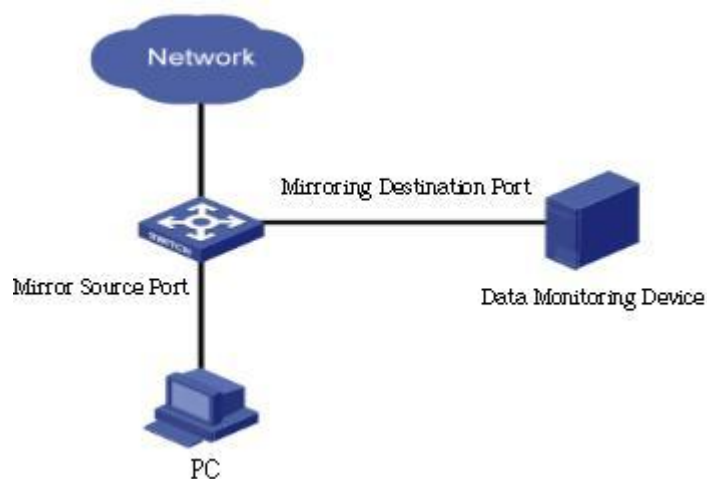

Instance

PC1 and PC2 access Switch A through interface GE1 and GE2 respectively.  
Users intend to monitor the messages transmitted from PC2 to PC1.

Instructions:

1. Click the “Port > Mirroring” in the navigation bar. 4 sets of flow mirroring rules can be configured as follows:

### Mirroring Table

|                       | Session ID | State    | Monitor Port  | Ingress Port | Egress Port |
|-----------------------|------------|----------|---------------|--------------|-------------|
| <input type="radio"/> | 1          | Enabled  | GE1 (Normal*) | GE2-GE4      | GE2-GE4     |
| <input type="radio"/> | 2          | Disabled | ---           | ---          | ---         |
| <input type="radio"/> | 3          | Disabled | ---           | ---          | ---         |
| <input type="radio"/> | 4          | Disabled | ---           | ---          | ---         |

\*\*\* Allow the monitor port to send or receive normal packets

2. Select one session and “Modify” it in the mirroring group configuration interface:

### Edit Mirroring

|                     |  |  |
|---------------------|--|--|
| <b>Session ID</b>   | 1  |  |
| <b>State</b>        | <input checked="" type="checkbox"/> Enable   |  |
| <b>Monitor Port</b> | GE1 <input type="button" value="v"/>   |  |
|                     | <input checked="" type="checkbox"/> Send or Receive Normal Packet  |  |
| <b>Ingress Port</b> | Available Port   | Selected Port  |
|                     | <div style="border: 1px solid #ccc; padding: 5px;">           GE1<br/>GE5<br/>GE6<br/>GE7<br/>GE8<br/>GE9<br/>GE10<br/>GE11         </div> | <div style="border: 1px solid #ccc; padding: 5px;">           GE2<br/>GE3<br/>GE4         </div> |
| <b>Egress Port</b>  | Available Port   | Selected Port  |
|                     | <div style="border: 1px solid #ccc; padding: 5px;">           GE1<br/>GE5<br/>GE6<br/>GE7<br/>GE8<br/>GE9<br/>GE10<br/>GE11         </div> | <div style="border: 1px solid #ccc; padding: 5px;">           GE2<br/>GE3<br/>GE4         </div> |

Interface data are as follows

| Configuration Items | Description   |
|---------------------|---|
| Session ID          | The switch has 4 session IDs by default.  |
| State               | The mirroring group can be enabled or not.  |
| Destination Port    | Only one ordinary physical port can be selected, excluding link aggregation port and source port. |
| Source Ingress Port | Any message received will be mirrored to the destination port.                                    |
| Source Egress Port  | Any message transmitted will be mirrored to the destination port.                                 |

## 4.5 Link Aggregation

### 4.5.1 About Link Aggregation

Link Aggregation broadens bandwidth and reliability by bundling a group of physical interfaces into a single logical interface.

LAG (Link Aggregation Group) is a logical link bundled by multiple Ethernet links (Eth-Trunk).

Ceaselessly expanding network size increases users' demands of link bandwidth and reliability. Traditionally, high-speed interface board or the compatible equipment is usually replaced to optimize bandwidth, which is expensive and inflexible.

Link Aggregation Technology bundles multiple physical interfaces into a single logical interface without upgrading hardware. Its backup mechanism not only improves reliability, but also shares the flow load on different physical links.

As shown below, Switch A is linked with Switch B through three Ethernet links which are bundled into an Eth-Trunk logical link. Its bandwidth equals to that of the three links in total, thus broadening the bandwidth. Meanwhile, these three links back up mutually to be more reliable.

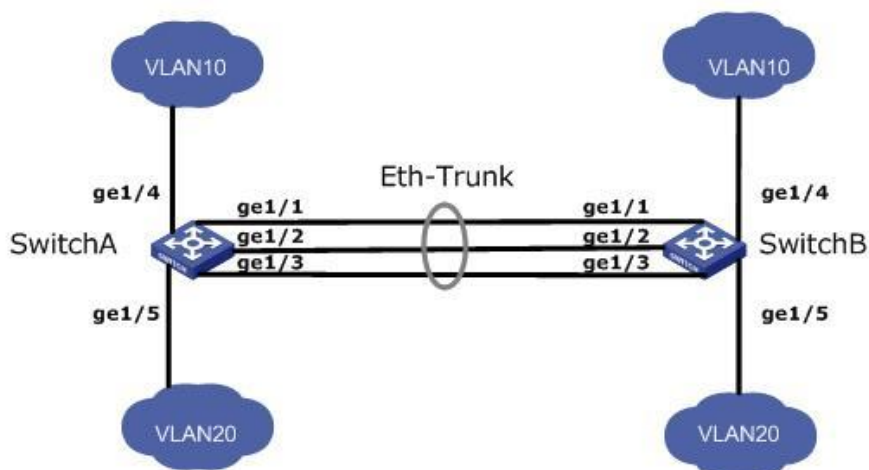

Link Aggregation can meet the following demands:

Insufficient bandwidth of two switches connected with one link.

Insufficient reliability of two switches connected with one link.

Link Aggregation can be divided into Manual Mode and LACP Mode in accordance with Link Aggregation Control Protocol (LACP) state.

In the first mode, Eth-Trunk establishment, member interface access should be added manually without LACP. It is also called the Load-sharing Mode because all links are involved in data forwarding and load sharing. In case any active link fails, LAG will average load with the remaining ones. This mode is preferred under the circumstance that two directly connected devices require a larger link bandwidth but has no access to LACP.

## 4.5.2 Add Static Link Aggregation

Instructions for adding a Static Link Aggregation:

1. Click the “Port > Aggregation > LAG Configuration”, select a load-balancing algorithm with a radio button. “Apply” and finish as follows:

**Load Balance Algorithm**

MAC Address  
 IP-MAC Address

### Link Aggregation Table

|                       | LAG   | Name | Type | Link Status | Active Member | Inactive Member |  |
|-----------------------|-------|------|------|-------------|---------------|-----------------|--|
| <input type="radio"/> | LAG 1 |      | ---  | ---         |               |                 |  |
| <input type="radio"/> | LAG 2 |      | ---  | ---         |               |                 |  |
| <input type="radio"/> | LAG 3 |      | ---  | ---         |               |                 |  |
| <input type="radio"/> | LAG 4 |      | ---  | ---         |               |                 |  |
| <input type="radio"/> | LAG 5 |      | ---  | ---         |               |                 |  |
| <input type="radio"/> | LAG 6 |      | ---  | ---         |               |                 |  |
| <input type="radio"/> | LAG 7 |      | ---  | ---         |               |                 |  |
| <input type="radio"/> | LAG 8 |      | ---  | ---         |               |                 |  |

2. Select one of 8 LAGs available, “Modify” the configuration page as follows:

### Edit Link Aggregation Group

Interface data are as follows

| Configuration Items | Description  |
|---------------------|--|
| LAG                 | There are 8 LAGs numbering from 1 to 8.              |
| Name                | Description of LAG, which can be modified as needed. |
| Mode                | Select from the manual mode and the LACP mode.       |
| Member              | Up to 8 member ports are available in LAG.           |

Illustration:

As shown below, Switch A and Switch B connect VLAN 10 and 20 via Ethernet respectively, with large data flow between them.

Both Switch A and B are expected to provide superior link bandwidth for VLAN communication. Meanwhile, there should be the redundancy for reliable data transmission and links.

Networking diagram LAG in manual mode

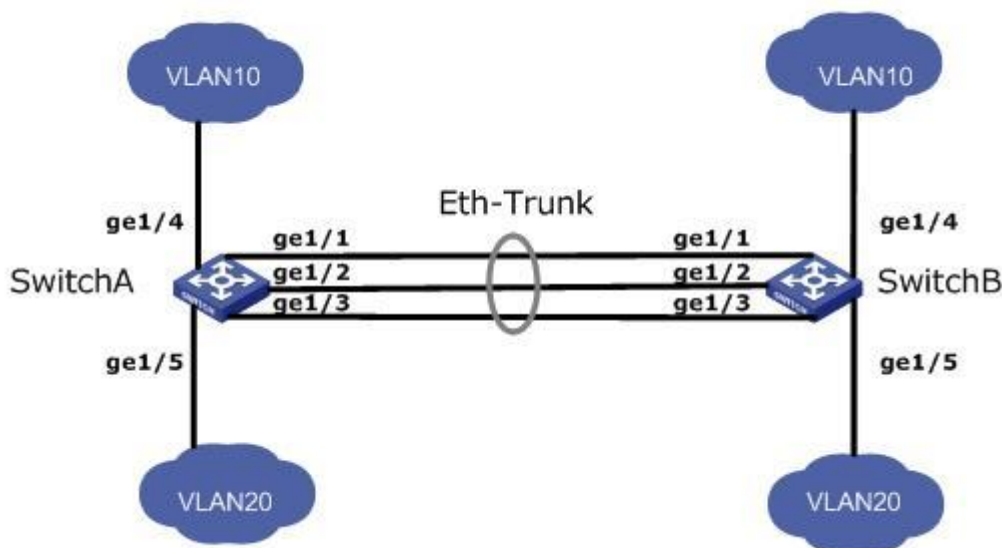

Instructions:

1. Similar to the steps of Switch B configuration, Switch A creates an Eth-Trunk interface and accesses member interfaces to broaden link bandwidth. Click the “Port > Aggregation > LAG Configuration”, choose “LAG 1” and port GE1, 2 and 3 and move them to the selected ports on the right. “Apply” and finish as follows.

#### Edit Link Aggregation Group

|               |  |                                    |
|---------------|--|------------------------------------|
| <b>LAG</b>    | 1  |                                    |
| <b>Name</b>   | <input type="text"/>   |                                    |
| <b>Type</b>   | <input checked="" type="radio"/> Static<br><input type="radio"/> LACP    |                                    |
| <b>Member</b> | Available Port<br>GE4<br>GE5<br>GE6<br>GE7<br>GE8<br>GE9<br>GE10<br>GE11 | Selected Port<br>GE1<br>GE2<br>GE3 |

Apply Close

### 4.5.3 Add Dynamic Link Aggregation

Dynamic Link Aggregation

LACP (Link Aggregation Control Protocol), based on IEEE 802.3ad Standard, dynamically

aggregates and disaggregates links. It exchanges info with the opposite network devices through LACPDU (Link Aggregation Control Protocol Data Unit).

After a port uses LACP, it will inform the opposite network device of system priority, system MAC, port priority and No., and operation Key by transmitting a LACPDU. The opposite device will compare such info with that saved by other ports after receiving it, thus reaching an agreement on port participation in or quitting from a dynamic aggregation.

Dynamic LACP aggregation is automatically created or deleted by system, that is, internal ports can be added or removed by themselves. Only the ports connected to a same device with the same rate, duplex, and basic configuration can be aggregated.

Instructions for adding a dynamic link aggregation:

1. Click the “Port > Aggregation > LAG Configuration” in the navigation bar, select the LAG ID and LACP mode, “Modify” them as follows:

#### Edit Link Aggregation Group

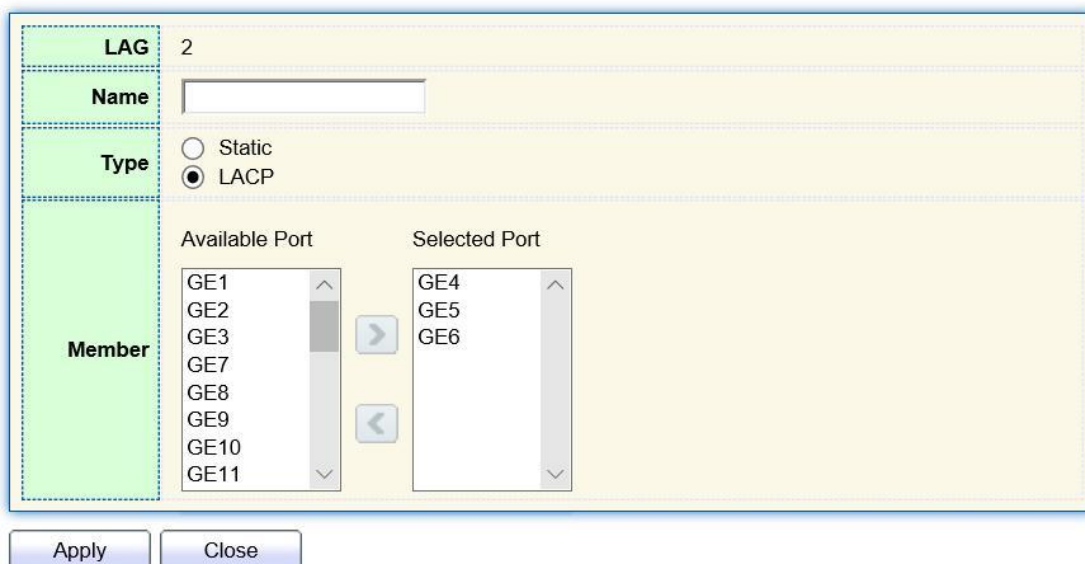

|               |  |                                    |
|---------------|--|------------------------------------|
| <b>LAG</b>    | 2  |                                    |
| <b>Name</b>   | <input type="text"/>   |                                    |
| <b>Type</b>   | <input type="radio"/> Static<br><input checked="" type="radio"/> LACP    |                                    |
| <b>Member</b> | Available Port<br>GE1<br>GE2<br>GE3<br>GE7<br>GE8<br>GE9<br>GE10<br>GE11 | Selected Port<br>GE4<br>GE5<br>GE6 |

Apply    Close

2. Click the “Port > Aggregation > LACP Configuration” in the navigation bar to configure the LACP attributes such as system priority, port priority and timeout method as follows:

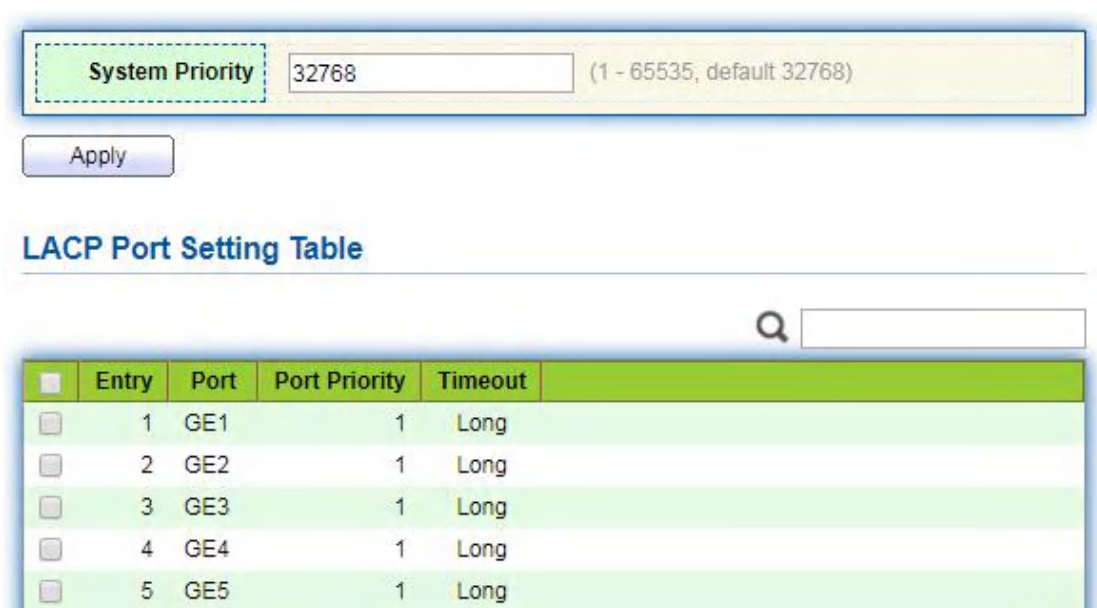

Interface data are as follows

| Configuration Items | Description   |
|---------------------|---|
| Mode                | <p>Static mode and LACP mode</p> <p>Static mode<br/>A static link aggregation should be created and the member interfaces should be added for better bandwidth and reliability between two devices in case LACP is unavailable to one of them.</p> <p>LACP mode<br/>Links between two devices are able to backup redundantly in the dynamic LACP mode. Backup links ensure the uninterrupted data transmission by replacing the partially failed links.</p> |
| System Priority     | LACP determines the active and passive modes between two devices subject to priority standard.  |
| Port Priority       | LACP determines the dynamic LAG member mode subject to the port priority with a superior system.  |
| Timeout Period      | It decides the transmission frequency of LACP messages.   |

Description:

Please make sure there is no member interface accessing the Eth-Trunk before changing its work pattern, otherwise it fails.

Work pattern of the local network devices should be consistent with that of the opposite network devices.

Illustration

Ethernet Switch A aggregates 3 ports from GE1 to GE3 to Switch B, so as to share the load by each member port.

The following configurations are exemplified by means of dynamic aggregation.

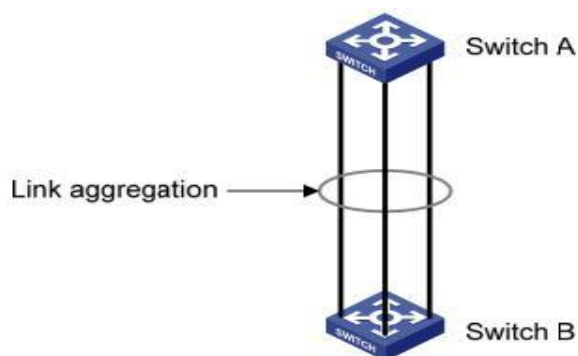

Instructions:

Description:

The following is the configuration of Switch A only, which should stay the same with that of Switch B for port aggregation.

Instructions:

1. Click the “Port > Aggregation > LAG Configuration” in the navigation bar, “Modify” with LAG 2, select GE1-GE3 in LACP mode. “Apply” and finish as follows:

#### Edit Link Aggregation Group

| <b>LAG</b>     | 1  |                |  |               |     |  |     |     |  |     |     |  |     |     |  |  |     |  |  |     |  |  |      |  |  |      |  |  |
|----------------|--|----------------|--|---------------|-----|--|-----|-----|--|-----|-----|--|-----|-----|--|--|-----|--|--|-----|--|--|------|--|--|------|--|--|
| <b>Name</b>    | <input type="text"/>   |                |  |               |     |  |     |     |  |     |     |  |     |     |  |  |     |  |  |     |  |  |      |  |  |      |  |  |
| <b>Type</b>    | <input type="radio"/> Static<br><input checked="" type="radio"/> LACP  |                |  |               |     |  |     |     |  |     |     |  |     |     |  |  |     |  |  |     |  |  |      |  |  |      |  |  |
| <b>Member</b>  | <table border="0"> <thead> <tr> <th>Available Port</th> <th></th> <th>Selected Port</th> </tr> </thead> <tbody> <tr> <td>GE4</td> <td></td> <td>GE1</td> </tr> <tr> <td>GE5</td> <td></td> <td>GE2</td> </tr> <tr> <td>GE6</td> <td></td> <td>GE3</td> </tr> <tr> <td>GE7</td> <td></td> <td></td> </tr> <tr> <td>GE8</td> <td></td> <td></td> </tr> <tr> <td>GE9</td> <td></td> <td></td> </tr> <tr> <td>GE10</td> <td></td> <td></td> </tr> <tr> <td>GE11</td> <td></td> <td></td> </tr> </tbody> </table> | Available Port |  | Selected Port | GE4 |  | GE1 | GE5 |  | GE2 | GE6 |  | GE3 | GE7 |  |  | GE8 |  |  | GE9 |  |  | GE10 |  |  | GE11 |  |  |
| Available Port |  | Selected Port  |  |               |     |  |     |     |  |     |     |  |     |     |  |  |     |  |  |     |  |  |      |  |  |      |  |  |
| GE4            |  | GE1            |  |               |     |  |     |     |  |     |     |  |     |     |  |  |     |  |  |     |  |  |      |  |  |      |  |  |
| GE5            |  | GE2            |  |               |     |  |     |     |  |     |     |  |     |     |  |  |     |  |  |     |  |  |      |  |  |      |  |  |
| GE6            |  | GE3            |  |               |     |  |     |     |  |     |     |  |     |     |  |  |     |  |  |     |  |  |      |  |  |      |  |  |
| GE7            |  |                |  |               |     |  |     |     |  |     |     |  |     |     |  |  |     |  |  |     |  |  |      |  |  |      |  |  |
| GE8            |  |                |  |               |     |  |     |     |  |     |     |  |     |     |  |  |     |  |  |     |  |  |      |  |  |      |  |  |
| GE9            |  |                |  |               |     |  |     |     |  |     |     |  |     |     |  |  |     |  |  |     |  |  |      |  |  |      |  |  |
| GE10           |  |                |  |               |     |  |     |     |  |     |     |  |     |     |  |  |     |  |  |     |  |  |      |  |  |      |  |  |
| GE11           |  |                |  |               |     |  |     |     |  |     |     |  |     |     |  |  |     |  |  |     |  |  |      |  |  |      |  |  |

Apply Close

## 4.6 Port Isolation

Messages of broadcast, multicast, etc. will flood at each port even though the flow needs no mutual communication sometimes. Under this circumstance, port isolation can separate the messages between two ports.

Instructions:

1. Click the “Port > Port Isolation” in the navigation bar, check the port(s) to be isolated,

“Modify” to switch this function as follows:

### Protected Port Table

| <input type="checkbox"/> | Entry | Port | State       |
|--------------------------|-------|------|-------------|
| <input type="checkbox"/> | 1     | GE1  | Unprotected |
| <input type="checkbox"/> | 2     | GE2  | Unprotected |
| <input type="checkbox"/> | 3     | GE3  | Unprotected |
| <input type="checkbox"/> | 4     | GE4  | Unprotected |
| <input type="checkbox"/> | 5     | GE5  | Unprotected |
| <input type="checkbox"/> | 6     | GE6  | Unprotected |
| <input type="checkbox"/> | 7     | GE7  | Unprotected |

### Edit Protected Port

|              |   |
|--------------|---|
| <b>Port</b>  | GE1-GE4                                       |
| <b>State</b> | <input checked="" type="checkbox"/> Protected |

The following figure illustrates that PC1, 2 and 3 access GE1, 2 and 3 severally, but they are expected to be isolated.

Instructions:

1. Click the “Port > Port Isolation” in the navigation bar, check and “Modify” the GE1, 2 and 3 to be isolated. “Apply” and finish as follows:

### Protected Port Table

| <input type="checkbox"/> | Entry | Port | State       |
|--------------------------|-------|------|-------------|
| <input type="checkbox"/> | 1     | GE1  | Protected   |
| <input type="checkbox"/> | 2     | GE2  | Protected   |
| <input type="checkbox"/> | 3     | GE3  | Protected   |
| <input type="checkbox"/> | 4     | GE4  | Unprotected |
| <input type="checkbox"/> | 5     | GE5  | Unprotected |

GE1, 2 and 3 fail to communicate mutually like other non-isolated ports.

## 4.7 Port Statistics

a. Introduce the detailed flow statistics of all ports and that to be refreshed or cleared manually by users.



Note: Cleared flow statistics cannot be restored. Please think twice before operation.

**Instructions:**

1. Click the “Device Management > RMON Configuration> Message Statistics” in the navigation bar as follows:

Statistics Table

Refresh Rate: 0 sec

| Entry                    | Port  | Bytes Received | Drop Events | Packets Received | Broadcast Packets | Multicast Packets | CRC & Align Errors | Undersize Packets | Oversize Packets | Fragments | Jabbers | Collisions | Frames of 64 Bytes | Frames of 65 to 127 Bytes | Frames of 128 to 255 Bytes | Frames of 256 to 511 Bytes | Frames of 512 to 1023 Bytes | Frames Greater than 1024 Bytes |   |
|--------------------------|-------|----------------|-------------|------------------|-------------------|-------------------|--------------------|-------------------|------------------|-----------|---------|------------|--------------------|---------------------------|----------------------------|----------------------------|-----------------------------|--------------------------------|---|
| <input type="checkbox"/> | 1 GE1 | 0              | 0           | 0                | 0                 | 0                 | 0                  | 0                 | 0                | 0         | 0       | 0          | 0                  | 0                         | 0                          | 0                          | 0                           | 0                              | 0 |
| <input type="checkbox"/> | 2 GE2 | 0              | 0           | 0                | 0                 | 0                 | 0                  | 0                 | 0                | 0         | 0       | 0          | 0                  | 0                         | 0                          | 0                          | 0                           | 0                              | 0 |
| <input type="checkbox"/> | 3 GE3 | 0              | 0           | 0                | 0                 | 0                 | 0                  | 0                 | 0                | 0         | 0       | 0          | 0                  | 0                         | 0                          | 0                          | 0                           | 0                              | 0 |
| <input type="checkbox"/> | 4 GE4 | 4190           | 0           | 57               | 28                | 29                | 0                  | 0                 | 0                | 0         | 0       | 0          | 0                  | 57                        | 0                          | 0                          | 0                           | 0                              | 0 |
| <input type="checkbox"/> | 5 GE5 | 0              | 0           | 0                | 0                 | 0                 | 0                  | 0                 | 0                | 0         | 0       | 0          | 0                  | 0                         | 0                          | 0                          | 0                           | 0                              | 0 |
| <input type="checkbox"/> | 6 GE6 | 0              | 0           | 0                | 0                 | 0                 | 0                  | 0                 | 0                | 0         | 0       | 0          | 0                  | 0                         | 0                          | 0                          | 0                           | 0                              | 0 |
| <input type="checkbox"/> | 7 GE7 | 0              | 0           | 0                | 0                 | 0                 | 0                  | 0                 | 0                | 0         | 0       | 0          | 0                  | 0                         | 0                          | 0                          | 0                           | 0                              | 0 |
| <input type="checkbox"/> | 8 GE8 | 0              | 0           | 0                | 0                 | 0                 | 0                  | 0                 | 0                | 0         | 0       | 0          | 0                  | 0                         | 0                          | 0                          | 0                           | 0                              | 0 |

**Description:**

- “Refresh” to get the updated flow statistics.
- “Clear” to remove the flow statistics at all ports and refresh the page.
- “View” the specified port for detailed flow statistics.

b. Introduce the detailed flow statistics at a port and the info to be refreshed or cleared manually by users.

1. Click the “System State > Port Info> Port Statistics” in the navigation bar as follows:

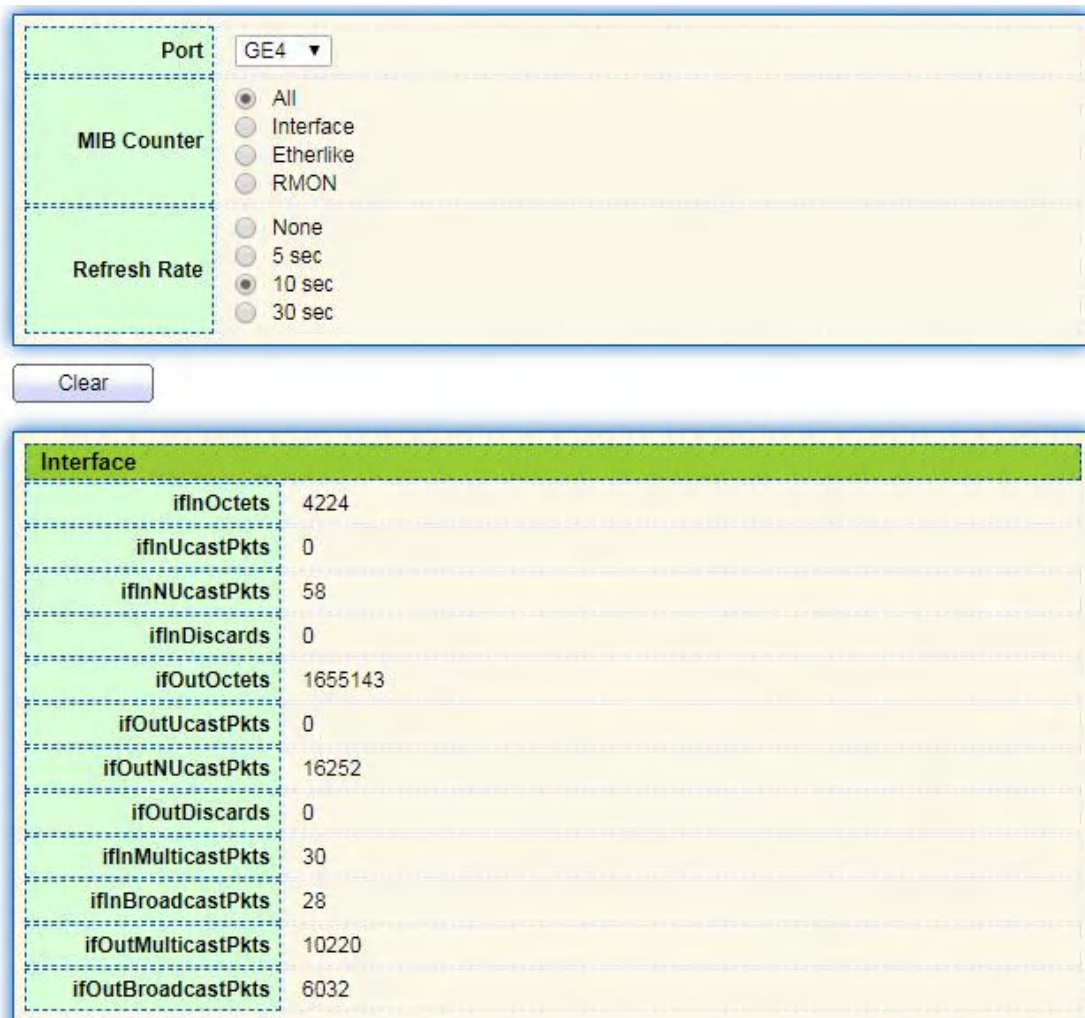

The screenshot shows a configuration panel for port GE4. It includes a 'Port' dropdown menu set to 'GE4', a 'MIB Counter' section with radio buttons for 'All', 'Interface', 'Etherlike', and 'RMON', and a 'Refresh Rate' section with radio buttons for 'None', '5 sec', '10 sec', and '30 sec'. Below this is a 'Clear' button. The second part of the screenshot is a table titled 'Interface' showing various statistics for the selected port.

| Interface          |         |
|--------------------|---------|
| ifInOctets         | 4224    |
| ifInUcastPkts      | 0       |
| ifInNUcastPkts     | 58      |
| ifInDiscards       | 0       |
| ifOutOctets        | 1655143 |
| ifOutUcastPkts     | 0       |
| ifOutNUcastPkts    | 16252   |
| ifOutDiscards      | 0       |
| ifInMulticastPkts  | 30      |
| ifInBroadcastPkts  | 28      |
| ifOutMulticastPkts | 10220   |
| ifOutBroadcastPkts | 6032    |

Description:

“Clear” the flow statistics at the current port and refresh the page.

## 5 PoE

PoE (Power over Ethernet) transmits data signal for the terminals based on IP (e.g. IP phone, WAP, and IP camera) and supplies the devices with direct current, without changing the existing Cat-5 network cabling status. It ensures safe structured cabling and normal network operation to minimize the cost.

### 5.1 PoE Port Setting

Instructions:

1. Click the “POE Setting > POE Port Setting” in the navigation bar as follows:

### System info

|                       |  |
|-----------------------|--|
| System Power(mW)      | 8164   |
| System Temperature(C) | 60   |
| Refresh Rate          | <input type="radio"/> None<br><input type="radio"/> 5 sec<br><input checked="" type="radio"/> 10 sec<br><input type="radio"/> 30 sec |

### Port Setting Table

| Entry                    | Port | PortEnable | Status  | Type | Level | Actual Power(mW) | Voltage(V) | Current(mA) | WatchDog |          |
|--------------------------|------|------------|---------|------|-------|------------------|------------|-------------|----------|----------|
| <input type="checkbox"/> | 1    | GE1        | Enabled | Off  | AF(U) | 0                | N/A        | N/A         | N/A      | Disabled |
| <input type="checkbox"/> | 2    | GE2        | Enabled | Off  | AF(U) | 0                | N/A        | N/A         | N/A      | Disabled |
| <input type="checkbox"/> | 3    | GE3        | Enabled | Off  | AF(U) | 0                | N/A        | N/A         | N/A      | Disabled |
| <input type="checkbox"/> | 4    | GE4        | Enabled | Off  | AF(U) | 0                | N/A        | N/A         | N/A      | Disabled |
| <input type="checkbox"/> | 5    | GE5        | Enabled | Off  | AF(U) | 0                | N/A        | N/A         | N/A      | Disabled |
| <input type="checkbox"/> | 6    | GE6        | Enabled | Off  | AF(U) | 0                | N/A        | N/A         | N/A      | Disabled |
| <input type="checkbox"/> | 7    | GE7        | Enabled | Off  | AF(U) | 0                | N/A        | N/A         | N/A      | Disabled |

2. Select the port(s) to be configured, and “Edit” as follows:

#### Edit Port Setting

|            |   |
|------------|---|
| Port       | GE1   |
| PortEnable | <input type="radio"/> Enable<br><input type="radio"/> Disable |
| WatchDog   | <input type="radio"/> Enable<br><input type="radio"/> Disable |

Apply Close

Configuration items are as follows.

| Configuration Items | Description  |
|---------------------|--|
| PortEnable          | Enable/Disable Poe port power  |
| WatchDog            | Enable/Disable Poe port watchdog function; After enabling the watchdog function, when the POE port is continuously powered but there is no traffic, the POE watchdog will be triggered. After 2 minutes of detection, the power supply will be stopped and then powered on. The total detection cycle is 5 times |

## 5.2 POE Port Timer Setting

Instructions:

1. Click the “POE Setting > POE Port Setting” , Select the power supply time of Poe

schedule. “Apply” and finish as follows:

Port

Q

| <input type="checkbox"/> | 00                                  | 01                                  | 02                                  | 03                                  | 04                                  | 05                                  | 06                                  | 07                                  | 08                                  | 09                                  | 10                                  | 11                                  | 12                                  | 13                                  | 14                                  | 15                                  | 16                                  | 17                                  | 18                                  | 19                                  | 20                                  | 21                                  | 22                                  | 23                                  |
|--------------------------|-------------------------------------|-------------------------------------|-------------------------------------|-------------------------------------|-------------------------------------|-------------------------------------|-------------------------------------|-------------------------------------|-------------------------------------|-------------------------------------|-------------------------------------|-------------------------------------|-------------------------------------|-------------------------------------|-------------------------------------|-------------------------------------|-------------------------------------|-------------------------------------|-------------------------------------|-------------------------------------|-------------------------------------|-------------------------------------|-------------------------------------|-------------------------------------|
| Mon                      | <input checked="" type="checkbox"/> | <input checked="" type="checkbox"/> | <input checked="" type="checkbox"/> | <input checked="" type="checkbox"/> | <input checked="" type="checkbox"/> | <input checked="" type="checkbox"/> | <input checked="" type="checkbox"/> | <input checked="" type="checkbox"/> | <input checked="" type="checkbox"/> | <input checked="" type="checkbox"/> | <input checked="" type="checkbox"/> | <input checked="" type="checkbox"/> | <input checked="" type="checkbox"/> | <input checked="" type="checkbox"/> | <input checked="" type="checkbox"/> | <input checked="" type="checkbox"/> | <input checked="" type="checkbox"/> | <input checked="" type="checkbox"/> | <input checked="" type="checkbox"/> | <input checked="" type="checkbox"/> | <input checked="" type="checkbox"/> | <input checked="" type="checkbox"/> | <input checked="" type="checkbox"/> | <input checked="" type="checkbox"/> |
| Tue                      | <input checked="" type="checkbox"/> | <input checked="" type="checkbox"/> | <input checked="" type="checkbox"/> | <input checked="" type="checkbox"/> | <input checked="" type="checkbox"/> | <input checked="" type="checkbox"/> | <input checked="" type="checkbox"/> | <input checked="" type="checkbox"/> | <input checked="" type="checkbox"/> | <input checked="" type="checkbox"/> | <input checked="" type="checkbox"/> | <input checked="" type="checkbox"/> | <input checked="" type="checkbox"/> | <input checked="" type="checkbox"/> | <input checked="" type="checkbox"/> | <input checked="" type="checkbox"/> | <input checked="" type="checkbox"/> | <input checked="" type="checkbox"/> | <input checked="" type="checkbox"/> | <input checked="" type="checkbox"/> | <input checked="" type="checkbox"/> | <input checked="" type="checkbox"/> | <input checked="" type="checkbox"/> | <input checked="" type="checkbox"/> |
| Wed                      | <input checked="" type="checkbox"/> | <input checked="" type="checkbox"/> | <input checked="" type="checkbox"/> | <input checked="" type="checkbox"/> | <input checked="" type="checkbox"/> | <input checked="" type="checkbox"/> | <input checked="" type="checkbox"/> | <input checked="" type="checkbox"/> | <input checked="" type="checkbox"/> | <input checked="" type="checkbox"/> | <input checked="" type="checkbox"/> | <input checked="" type="checkbox"/> | <input checked="" type="checkbox"/> | <input checked="" type="checkbox"/> | <input checked="" type="checkbox"/> | <input checked="" type="checkbox"/> | <input checked="" type="checkbox"/> | <input checked="" type="checkbox"/> | <input checked="" type="checkbox"/> | <input checked="" type="checkbox"/> | <input checked="" type="checkbox"/> | <input checked="" type="checkbox"/> | <input checked="" type="checkbox"/> | <input checked="" type="checkbox"/> |
| Thu                      | <input checked="" type="checkbox"/> | <input checked="" type="checkbox"/> | <input checked="" type="checkbox"/> | <input checked="" type="checkbox"/> | <input checked="" type="checkbox"/> | <input checked="" type="checkbox"/> | <input checked="" type="checkbox"/> | <input checked="" type="checkbox"/> | <input checked="" type="checkbox"/> | <input checked="" type="checkbox"/> | <input checked="" type="checkbox"/> | <input checked="" type="checkbox"/> | <input checked="" type="checkbox"/> | <input checked="" type="checkbox"/> | <input checked="" type="checkbox"/> | <input checked="" type="checkbox"/> | <input checked="" type="checkbox"/> | <input checked="" type="checkbox"/> | <input checked="" type="checkbox"/> | <input checked="" type="checkbox"/> | <input checked="" type="checkbox"/> | <input checked="" type="checkbox"/> | <input checked="" type="checkbox"/> | <input checked="" type="checkbox"/> |
| Fri                      | <input checked="" type="checkbox"/> | <input checked="" type="checkbox"/> | <input checked="" type="checkbox"/> | <input checked="" type="checkbox"/> | <input checked="" type="checkbox"/> | <input checked="" type="checkbox"/> | <input checked="" type="checkbox"/> | <input checked="" type="checkbox"/> | <input checked="" type="checkbox"/> | <input checked="" type="checkbox"/> | <input checked="" type="checkbox"/> | <input checked="" type="checkbox"/> | <input checked="" type="checkbox"/> | <input checked="" type="checkbox"/> | <input checked="" type="checkbox"/> | <input checked="" type="checkbox"/> | <input checked="" type="checkbox"/> | <input checked="" type="checkbox"/> | <input checked="" type="checkbox"/> | <input checked="" type="checkbox"/> | <input checked="" type="checkbox"/> | <input checked="" type="checkbox"/> | <input checked="" type="checkbox"/> | <input checked="" type="checkbox"/> |
| Sat                      | <input checked="" type="checkbox"/> | <input checked="" type="checkbox"/> | <input checked="" type="checkbox"/> | <input checked="" type="checkbox"/> | <input checked="" type="checkbox"/> | <input checked="" type="checkbox"/> | <input checked="" type="checkbox"/> | <input checked="" type="checkbox"/> | <input checked="" type="checkbox"/> | <input checked="" type="checkbox"/> | <input checked="" type="checkbox"/> | <input checked="" type="checkbox"/> | <input checked="" type="checkbox"/> | <input checked="" type="checkbox"/> | <input checked="" type="checkbox"/> | <input checked="" type="checkbox"/> | <input checked="" type="checkbox"/> | <input checked="" type="checkbox"/> | <input checked="" type="checkbox"/> | <input checked="" type="checkbox"/> | <input checked="" type="checkbox"/> | <input checked="" type="checkbox"/> | <input checked="" type="checkbox"/> | <input checked="" type="checkbox"/> |
| Sun                      | <input checked="" type="checkbox"/> | <input checked="" type="checkbox"/> | <input checked="" type="checkbox"/> | <input checked="" type="checkbox"/> | <input checked="" type="checkbox"/> | <input checked="" type="checkbox"/> | <input checked="" type="checkbox"/> | <input checked="" type="checkbox"/> | <input checked="" type="checkbox"/> | <input checked="" type="checkbox"/> | <input checked="" type="checkbox"/> | <input checked="" type="checkbox"/> | <input checked="" type="checkbox"/> | <input checked="" type="checkbox"/> | <input checked="" type="checkbox"/> | <input checked="" type="checkbox"/> | <input checked="" type="checkbox"/> | <input checked="" type="checkbox"/> | <input checked="" type="checkbox"/> | <input checked="" type="checkbox"/> | <input checked="" type="checkbox"/> | <input checked="" type="checkbox"/> | <input checked="" type="checkbox"/> | <input checked="" type="checkbox"/> |

## 6 L2 Configuration

### 6.1 VLAN Configuration

VLAN is formulated not restricted to physical locations, which means the hosts in a same VLAN can be placed at will. As shown below, each VLAN, as a broadcast domain, divides a physical LAN into logical LANs. Hosts can exchange messages by means of traditional communication. For the hosts in different VLANs, the device such as router or L3 switch is a must.

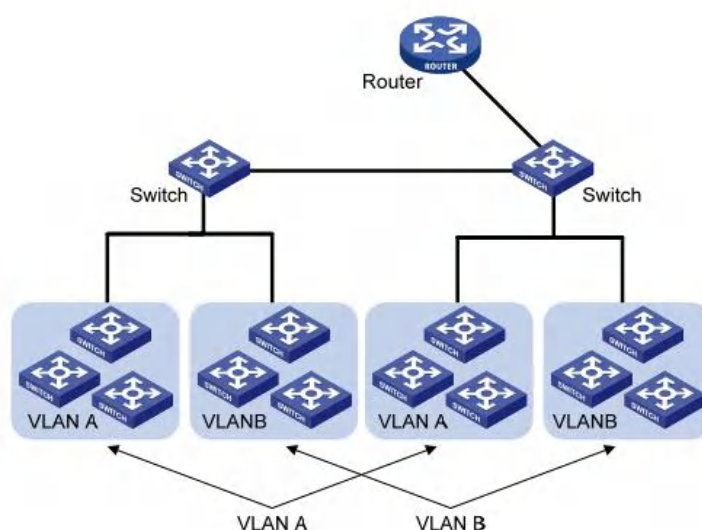

VLAN is superior to the traditional Ethernet in terms of:

**Broadcast domain coverage:** the broadcast message in a LAN is limited in a VLAN to save the bandwidth and handle the network-related issues more efficiently.

**LAN security:** VLAN hosts fail to communicate with each other since the messages are separated by the broadcast domain in the data link layer. They need a router or a Layer 3 switch for Layer 3 forwarding.

**Flexibility of creating a virtual working team:** VLAN can create a virtual working team beyond the control of physical network. Users have access to the network without changing the configuration if their physical locations are moving within the scope.

This management switch is compatible with VLAN types based on 802.1Q, protocols, MAC, and ports. For default configuration, 802.1Q VLAN mode should be adopted.

Port VLAN is divided subject to a switch's interface No. Network administrator gives each switch interface a different PVID, namely a port default VLAN. If a data frame without a VLAN tag flows into a switch interface with a PVID, it will be marked with the same PVID, or it will get rid of an additional tag even though the interface has a PVID.

The solution to a VLAN frame depends on the interface type, which eases member definition but re-configures VLAN in case of member mobility.

a. Instructions for creating a new VLAN:

- Click the “VLAN Function > VLAN Configuration > VLAN Creating” to select a name in the valid VLAN box, move it to the VLAN creating box on the right (up to 256 VLANs can be created). “Apply” and finish as follows:

### VLAN Table

Showing  entries      Showing 1 to 2 of 2 entries

| VLAN                    | Name     | Type    | VLAN Interface State |
|-------------------------|----------|---------|----------------------|
| <input type="radio"/> 1 | default  | Default | Disabled             |
| <input type="radio"/> 2 | VLAN0002 | Static  | Disabled             |

- The VLAN created will be displayed in the VLAN Table. Users can “Modify” the VLAN as follows:

### Edit VLAN Name

Interface data are as follows.

| Configuration Items | Description  |
|---------------------|--|
| VLAN ID             | It is required to select an ID ranging from 1 to 4,094. For example, 1-3,5,7 and 9. LAN 1 is the default, which won't be repeated in another new VLAN. |
| Name                | It is optional to modify the VLAN description as required.   |

- Instructions for adding the current port to a specified VLAN

There are two methods. One is to add multiple ports under a single VLAN. The other is to add a port to multiple VLANs. They are configured according to different purposes.

The first method:

- Click the “VLAN Function > VLAN Configuration > VLAN Setting” in the navigation tree, select the VLAN ID on the upper left, and then click the port info as follows:

## VLAN Configuration Table

VLAN default ▾



| Entry | Port | Mode  | Membership                     |                              |   | PVID                                | Forbidden                |
|-------|------|-------|--------------------------------|------------------------------|---|-------------------------------------|--------------------------|
| 1     | GE1  | Trunk | <input type="radio"/> Excluded | <input type="radio"/> Tagged | <input checked="" type="radio"/> Untagged | <input checked="" type="checkbox"/> | <input type="checkbox"/> |
| 2     | GE2  | Trunk | <input type="radio"/> Excluded | <input type="radio"/> Tagged | <input checked="" type="radio"/> Untagged | <input checked="" type="checkbox"/> | <input type="checkbox"/> |
| 3     | GE3  | Trunk | <input type="radio"/> Excluded | <input type="radio"/> Tagged | <input checked="" type="radio"/> Untagged | <input checked="" type="checkbox"/> | <input type="checkbox"/> |
| 4     | GE4  | Trunk | <input type="radio"/> Excluded | <input type="radio"/> Tagged | <input checked="" type="radio"/> Untagged | <input checked="" type="checkbox"/> | <input type="checkbox"/> |
| 5     | GE5  | Trunk | <input type="radio"/> Excluded | <input type="radio"/> Tagged | <input checked="" type="radio"/> Untagged | <input checked="" type="checkbox"/> | <input type="checkbox"/> |
| 6     | GE6  | Trunk | <input type="radio"/> Excluded | <input type="radio"/> Tagged | <input checked="" type="radio"/> Untagged | <input checked="" type="checkbox"/> | <input type="checkbox"/> |
| 7     | GE7  | Trunk | <input type="radio"/> Excluded | <input type="radio"/> Tagged | <input checked="" type="radio"/> Untagged | <input checked="" type="checkbox"/> | <input type="checkbox"/> |
| 8     | GE8  | Trunk | <input type="radio"/> Excluded | <input type="radio"/> Tagged | <input checked="" type="radio"/> Untagged | <input checked="" type="checkbox"/> | <input type="checkbox"/> |

Interface data are as follows.

| Configuration Items | Description   |
|---------------------|---|
| VLAN                | VLAN ID to be configured  |
| Member              | Member roles at the VLAN port:<br>Excluded: the port is out of this VLAN<br>Tagged: the port is a tagged member of this VLAN<br>Untagged: the port is an untagged member of this VLAN |
| PVID                | Whether this VLAN is the port PVID  |
| Forbidden           | Whether the VLAN message is forbidden to be forwarded at this port  |

The second method:

1. Click the “VLAN Function > VLAN Configuration > Member Configuration” in the navigation tree, select the port to be configured and “Modify” to configure its attributes:

### Edit Port Setting

Interface data are as follows.

| Configuration Items | Description   |
|---------------------|---|
| Port                | Port No. to be configured   |
| Mode                | <p>Modify the current VLAN mode in port configuration:</p> <p>Hybrid: port in this mode can serve as the Tagged &amp; Untagged members of VLANs.</p> <p>Access: port in this mode serves as the only one member of VLAN</p> <p>Trunk: port in this mode serves as the Untagged member of PVID only and the Tagged member of VLANs</p> |
| Member              | <p>The port is the attribute of VLAN ID and VLAN:</p> <p>Forbidden: do not forward the VLAN message</p> <p>Excluded: the port out of the VLAN</p> <p>Tagged: the Tagged member of the VLAN</p> <p>Untagged: the Untagged member of the VLAN</p> <p>PVID: whether the VLAN is the port PVLAN</p>                                       |

#### c. Introduction to 802.1q

Trunk configuration. Connected with other switches, Trunk interfaces mainly connect trunk links to allow the VLAN frames to flow through. IEEE 802.1q is the encapsulation protocol of Trunk link and considers the formal standard for Virtual Bridged Local Area Networks. It changes the frame format of Ethernet by adding a 4-bit 802.1q Tag between the source MAC address field and the protocol field.

802.1q frame format

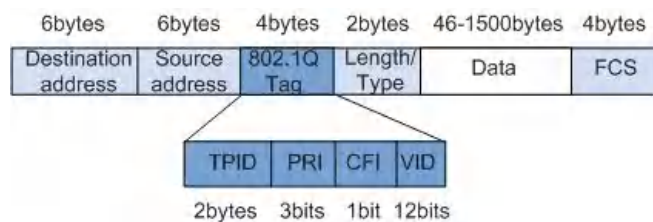

### Meanings of 802.1q tag fields

| Field | Length  | Name  | Analysis  |
|-------|---------|---|---|
| TPID  | 2 bytes | Tag Protocol Identifier to describe the frame type                                | It refers to the 802.1q Tag frame when the value is 0x8,100, which will be discarded if relevant equipment fails to receive it.   |
| PRI   | 3 bits  | Frame Priority  | It ranges from 0 to 7, with the higher priority represented by larger number. Data frame with higher priority will be sent preferentially in case of switch congestion. |
| CFI   | 1 bit   | Canonical Format Indicator to reveal whether the MAC address is classical or not. | MAC address is classical when CFI is 0 and non-classical when CFI is 1. It promotes the compatibility between Ethernet and token ring. CFI will be 0 in the Ethernet.   |
| VID   | 12 bits | VLAN ID indicates the VLAN to which the frame belongs.                            | It ranges from 0 to 4,095, with 1 to 4,094 valid since 0 and 4,095 are the protocol retention values.   |

Packets sent by each switch supporting 802.1q protocol contain a VLAN ID to indicate the VLAN to which the switch belongs. Therefore, Ethernet frames are divided into two types as follows in a VLAN switching network:

Tagged frame: it refers to the frame adding a 4-bit 802.1q Tag.

Untagged frame: it refers to the original frame without a 4-bit 802.1q Tag.

Connected with other switches, Trunk interfaces mainly connect trunk links to allow the VLAN frames to flow through.

d. Instructions for trunk interface configuration:

- Click the “VLAN Function > VLAN Configuration > Port Configuration” in the navigation tree, select the port and “Modify” it to configure the attributes:

## Port Setting Table

| <input type="checkbox"/> | Entry | Port | Mode  | PVID | Accept Frame Type | Ingress Filtering | Uplink   | TPID   |
|--------------------------|-------|------|-------|------|-------------------|-------------------|----------|--------|
| <input type="checkbox"/> | 1     | GE1  | Trunk | 1    | All               | Enabled           | Disabled | 0x8100 |
| <input type="checkbox"/> | 2     | GE2  | Trunk | 1    | All               | Enabled           | Disabled | 0x8100 |
| <input type="checkbox"/> | 3     | GE3  | Trunk | 1    | All               | Enabled           | Disabled | 0x8100 |
| <input type="checkbox"/> | 4     | GE4  | Trunk | 1    | All               | Enabled           | Disabled | 0x8100 |
| <input type="checkbox"/> | 5     | GE5  | Trunk | 1    | All               | Enabled           | Disabled | 0x8100 |
| <input type="checkbox"/> | 6     | GE6  | Trunk | 1    | All               | Enabled           | Disabled | 0x8100 |
| <input type="checkbox"/> | 7     | GE7  | Trunk | 1    | All               | Enabled           | Disabled | 0x8100 |
| <input type="checkbox"/> | 8     | GE8  | Trunk | 1    | All               | Enabled           | Disabled | 0x8100 |

## Edit Port Setting

|                          |  |
|--------------------------|--|
| <b>Port</b>              | GE4-GE8  |
| <b>Mode</b>              | <input checked="" type="radio"/> Hybrid<br><input type="radio"/> Access<br><input type="radio"/> Trunk<br><input type="radio"/> Tunnel |
| <b>PVID</b>              | <input type="text" value="1"/> (1 - 4094)  |
| <b>Accept Frame Type</b> | <input checked="" type="radio"/> All<br><input type="radio"/> Tag Only<br><input type="radio"/> Untag Only                             |
| <b>Ingress Filtering</b> | <input checked="" type="checkbox"/> Enable   |
| <b>Uplink</b>            | <input type="checkbox"/> Enable  |
| <b>TPID</b>              | <input type="text" value="v"/>   |

Interface data are as follows.

| Configuration Items | Description  |
|---------------------|--|
| Port                | Port No. to be configured  |
| Mode                | Modify the current VLAN mode in the port configuration:<br>Hybrid: port in this mode serves as the member of Tagged and Untagged ports of VLANs<br>Access: port in this mode serves as the only member of VLAN<br>Trunk: port in this mode serves as the only Untagged member of PVID and the Tagged member of VLANs |
| PVID                | Port PVLAN   |
| Accept Frame Type   | Message types received by ports<br>All: all messages   |

|                   |  |
|-------------------|--|
|                   | Tag Only: only Tagged messages will be received<br>Untag Only: only Untagged messages will be received |
| Ingress Filtering | A switch to decided to filter VLAN messages excluded at the port                                       |
| Uplink            | Whether in uplink mode or not  |
| TPID              | Identification No. of VLAN Tag   |

### Illustration

Connection interfaces and 2 VLANs should be added to support the user communication in VLAN 2 and 3 of the links between Switch A and B. That is, VLAN 2 and 3 should be added to the GE1-3 Ethernet Interfaces of Switch A and B.

### Instructions:

Create VLAN 2 and 3 in Switch A and B. Add GE1 port connected to user interfaces to VLAN2, with GE2 to VLAN3. Set GE3 in the trunk work pattern and add it to VLAN2 and 3.

## 6.2 MAC VLAN

MAC-based VLANs are divided subject to the MAC addresses in the network card. Administrators will prepare the mapping scheme between MAC address and VLAN ID which will be added if the switch receives untagged frames.

Strength: There is no need to re-configure VLAN when the physical location of a terminal user changes, which ensures user security and access flexibility. Shortcoming: It applies to the scene where network card and simple network environment are infrequently replaced, with members defined in advance.

### Instructions:

1. Click the “VLAN Function > MAC VLAN Configuration > MAC Group Configuration” in the navigation tree, and “Add” a new MAC group as follows:

### MAC Group Table

Showing  entries      Showing 1 to 1 of 1 entries     

| <input type="checkbox"/> | Group ID | MAC Address       | Mask |
|--------------------------|----------|-------------------|------|
| <input type="checkbox"/> | 1        | 00:0A:5A:00:00:00 | 24   |

### Add MAC Group

|                    |   |
|--------------------|---|
| <b>Group ID</b>    | <input type="text" value="2"/> (1 - 2147483647) |
| <b>MAC Address</b> | <input type="text" value="00:22:00:22:00:22"/>  |
| <b>Mask</b>        | <input type="text" value="48"/> × (9 - 48)      |

Interface data are as follows.

| Configuration Items | Description  |
|---------------------|--|
| Group ID            | MAC VLAN Group ID  |
| MAC Address         | The MAC address to be bound with VLAN  |
| Mask                | It indicates the MAC address port. Enter 48 if it is an exact match. Others should be consistent with the masks of IP addresses. |

For example, a company with high info security requirements allows its PCs only to access the internal network. As is shown, switch GE1 connects the uplink ports of Switch A while its downstream ports connect PC1, 2 and 3. As a result, PC1, 2 and 3 can access the internal network through Switch A and Switch, while other PCs can't.

Configuration logic: following steps are used to divide the VLAN based on MAC address.

2. Create a relevant VLAN.
3. Add Ethernet interfaces to the VLAN in a correct way.
4. Connect the VLAN with the MAC addresses of PC1, 2 and 3.

Data preparation: following data should be prepared for the configuration instance:

Set GE1 PVID of 100 on the switch.

Set GE1 to access VLAN10 in the Untagged way on the switch.

Set GE2 to access VLAN10 in the Tagged way on the switch.

Set the Switch A interface by default, namely all interfaces will be added to VLAN1 in an Untagged way.

Connect the MAC addresses of PC1, 2 and 3 with VLAN10.

Draw a networking diagram for VLAN division based on MAC addresses:

Instructions:

1. Create a VLAN to recognize the VLANs where employees belong. Click the “VLAN Function > VLAN Configuration > VLAN Creating” in the navigation tree, add VLAN10 to the VLAN Creating List on the right, “Apply” and finish as follows:

VLAN

Available VLAN

- VLAN 11
- VLAN 12
- VLAN 13
- VLAN 14
- VLAN 15
- VLAN 16
- VLAN 17
- VLAN 18

Created VLAN

- VLAN 3
- VLAN 4
- VLAN 5
- VLAN 6
- VLAN 7
- VLAN 8
- VLAN 9
- VLAN 10

- Configure Switch's GE1 in Hybrid mode with PVID of 100 to serve as an Untagged member of VLAN10. Configure GE2 in Trunk mode to serve as a Tagged member of VLAN10.

#### Port Setting Table

| <input type="checkbox"/> | Entry | Port | Mode   | PVID | Accept Frame Type | Ingress Filtering | Uplink   | TPID   |
|--------------------------|-------|------|--------|------|-------------------|-------------------|----------|--------|
| <input type="checkbox"/> | 1     | GE1  | Hybrid | 100  | All               | Enabled           | Disabled | 0x8100 |
| <input type="checkbox"/> | 2     | GE2  | Trunk  | 1    | All               | Enabled           | Disabled | 0x8100 |

#### Membership Table

| <input type="checkbox"/> | Entry | Port | Mode   | Administrative VLAN | Operational VLAN |
|--------------------------|-------|------|--------|---------------------|------------------|
| <input type="radio"/>    | 1     | GE1  | Hybrid | 1U, 10U, 100P       | 1U, 10U, 100P    |
| <input type="radio"/>    | 2     | GE2  | Trunk  | 1UP, 10T            | 1UP, 10T         |
| <input type="radio"/>    | 3     | GE3  | Trunk  | 1UP                 | 1UP              |

- Configure the Switch A's interfaces by default, namely all interfaces access VLAN1 in an Untagged way. Connect the MAC addresses of PC1, 2 and 3 with VLAN10. Click the "VLAN Function > MAC VLAN Configuration > MAC Group Configuration" in the navigation tree, enter the MAC addresses of PC1 (0022-0022-0022), PC2 (0033-0033-0033) and PC3 (0044-0044-0044), with the mask of 48-bit exact match as follows:

#### MAC Group Table

Showing  entries
Showing 1 to 3 of 3 entries

| <input type="checkbox"/> | Group ID | MAC Address       | Mask |
|--------------------------|----------|-------------------|------|
| <input type="checkbox"/> | 1        | 00:22:00:22:00:22 | 48   |
| <input type="checkbox"/> | 2        | 00:33:00:33:00:33 | 48   |
| <input type="checkbox"/> | 3        | 00:44:00:44:00:44 | 48   |

- Click the “VLAN Function > MAC VLAN Configuration > MAC Group Binding” in the navigation tree, “Add” to select the Hybrid port only, MAC group ID to be bound, and specified VLAN ID. “Apply” and finish:

### MAC Group Table

Showing  entries      Showing 1 to 3 of 3 entries     

| <input type="checkbox"/> | Group ID | MAC Address       | Mask |
|--------------------------|----------|-------------------|------|
| <input type="checkbox"/> | 1        | 00:22:00:22:00:22 | 48   |
| <input type="checkbox"/> | 2        | 00:33:00:33:00:33 | 48   |
| <input type="checkbox"/> | 3        | 00:44:00:44:00:44 | 48   |

- Configuration verification  
Only PC1, 2 and 3 have access to the internal network.

## 6.3 Protocol VLAN

Protocol-based VLAN distributes different VLAN IDs according to the protocol (family) type and encapsulation format of the messages received by the interfaces.

Administrators should prepare the mapping scheme between the protocol domain of Ethernet frame and VLAN ID which will be added if untagged frames are received. Strength: Such division method will enhance the management and maintenance by binding the network services and VLANs. Shortcomings: Initial configuration of the mapping relation scheme is necessary. Address formats of protocols should be analyzed and converted, thus leading to a lower speed due to a large number of resources consumed.

Instructions:

- Click the “VLAN Function > Protocol VLAN Configuration > Protocol Group Configuration” in the navigation tree as follows:

### Protocol Group Table

Showing  entries      Showing 1 to 1 of 1 entries     

| <input type="checkbox"/> | Group ID | Frame Type  | Protocol Value |
|--------------------------|----------|-------------|----------------|
| <input type="checkbox"/> | 1        | Ethernet_II | 0x8888         |

### Add Protocol Group

|                       |   |
|-----------------------|---|
| <b>Group ID</b>       | 2   |
| <b>Frame Type</b>     | Ethernet_II                               |
| <b>Protocol Value</b> | 0x <input type="text"/> (0x600 ~ 0xFFFFE) |

Interface data are as follows.

| Configuration Items | Description                        |
|---------------------|------------------------------------|
| Group ID            | Protocol VLAN Group                |
| Message Type        | Frame types: Ether2, LLC, RFC 1042 |
| Protocol Value      | It ranges from 0x600 to 0xFFFFE    |

- Fill in corresponding configuration items.
- “Apply” and finish.

### Protocol Group Table

Showing  entries      Showing 1 to 2 of 2 entries     

| <input type="checkbox"/> | Group ID | Frame Type  | Protocol Value |
|--------------------------|----------|-------------|----------------|
| <input type="checkbox"/> | 1        | Ethernet_II | 0x8888         |
| <input type="checkbox"/> | 2        | RFC_1042    | 0x8889         |

- Click the “VLAN Function > Protocol VLAN Configuration > Protocol Group Binding” in the navigation tree to bind the protocol No., port No. and VLAN ID, to bring the configuration into effect as follows:

### Group Binding Table

Showing  entries      Showing 1 to 1 of 1 entries     

| <input type="checkbox"/> | Port | Group ID | VLAN |
|--------------------------|------|----------|------|
| <input type="checkbox"/> | GE1  | 1        | 10   |

### Add Group Binding

|   |                |               |
|---|----------------|---------------|
| Port  | Available Port | Selected Port |
|   | GE1            |               |
| Group ID  | 1              |               |
| VLAN  |                |               |
| Note: Only VLAN Hybrid port can be set Protocol VLAN                      |                |               |
| <input type="button" value="Apply"/> <input type="button" value="Close"/> |                |               |

Description:

Configure the matching protocols IPv4 and IPv6, as well as the ARP protocol.

For example, PC1 and 3 can access mutually, with IPv4 communication protocol binding with VLAN10. PC2 and 4 can access mutually, with IPv6 communication protocol binding with VLAN20.

Networking diagram of protocol VLAN division

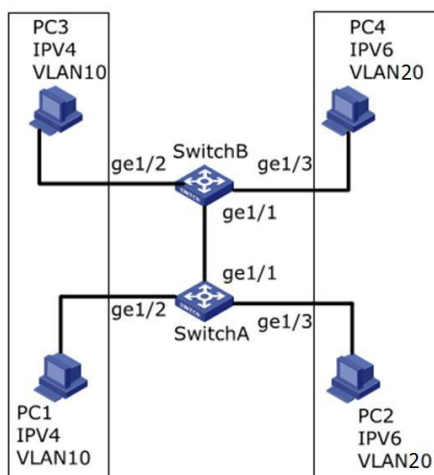

Instructions:

1. Create a VLAN to recognize the VLANs where employees belong. Click the “VLAN Function > VLAN Configuration > VLAN Creating”, add the VLAN10 and 20 to the VLAN Creating List on the right, “Apply” and finish:

VLAN

Available VLAN

- VLAN 2
- VLAN 3
- VLAN 4
- VLAN 5
- VLAN 6
- VLAN 7
- VLAN 8
- VLAN 9

Created VLAN

- VLAN 1
- VLAN 10
- VLAN 20

### VLAN Table

Showing All entries Showing 1 to 3 of 3 entries

| VLAN                     | Name     | Type    | VLAN Interface State |
|--------------------------|----------|---------|----------------------|
| <input type="radio"/> 1  | default  | Default | Disabled             |
| <input type="radio"/> 10 | VLAN0010 | Static  | Disabled             |
| <input type="radio"/> 20 | VLAN0020 | Static  | Disabled             |

2. Configure GE2 and GE3 interfaces of Switch A in Hybrid mode. Click the “VLAN Function > VLAN Configuration > Port Configuration”, “Modify” the interfaces in Hybrid mode:

### Port Setting Table

| <input type="checkbox"/> | Entry | Port | Mode   | PVID | Accept Frame Type | Ingress Filtering | Uplink   | TPID   |
|--------------------------|-------|------|--------|------|-------------------|-------------------|----------|--------|
| <input type="checkbox"/> | 1     | GE1  | Trunk  | 1    | All               | Enabled           | Disabled | 0x8100 |
| <input type="checkbox"/> | 2     | GE2  | Hybrid | 1    | All               | Enabled           | Disabled | 0x8100 |
| <input type="checkbox"/> | 3     | GE3  | Hybrid | 1    | All               | Enabled           | Disabled | 0x8100 |
| <input type="checkbox"/> | 4     | GE4  | Trunk  | 1    | All               | Enabled           | Disabled | 0x8100 |
| <input type="checkbox"/> | 5     | GE5  | Trunk  | 1    | All               | Enabled           | Disabled | 0x8100 |

3. Add the Untagged GE2 and GE3 to VLAN10 and VLAN20 respectively. Click the “VLAN Function > VLAN Configuration > VLAN Setting”, drop down the list to choose VLAN10 and the Untagged GE2 port. Following the same steps, add the untagged GE3 to VLAN20 as follows:

### VLAN Configuration Table

VLAN VLAN0010

| Entry | Port | Mode   | Membership                                |                              |   | PVID                     | Forbidden                |
|-------|------|--------|---|------------------------------|---|--------------------------|--------------------------|
| 1     | GE1  | Trunk  | <input checked="" type="radio"/> Excluded | <input type="radio"/> Tagged | <input type="radio"/> Untagged            | <input type="checkbox"/> | <input type="checkbox"/> |
| 2     | GE2  | Hybrid | <input type="radio"/> Excluded            | <input type="radio"/> Tagged | <input checked="" type="radio"/> Untagged | <input type="checkbox"/> | <input type="checkbox"/> |
| 3     | GE3  | Hybrid | <input checked="" type="radio"/> Excluded | <input type="radio"/> Tagged | <input type="radio"/> Untagged            | <input type="checkbox"/> | <input type="checkbox"/> |

### VLAN Configuration Table

VLAN VLAN0020

| Entry | Port | Mode   | Membership                                |                              |   | PVID                     | Forbidden                |
|-------|------|--------|---|------------------------------|---|--------------------------|--------------------------|
| 1     | GE1  | Trunk  | <input checked="" type="radio"/> Excluded | <input type="radio"/> Tagged | <input type="radio"/> Untagged            | <input type="checkbox"/> | <input type="checkbox"/> |
| 2     | GE2  | Hybrid | <input checked="" type="radio"/> Excluded | <input type="radio"/> Tagged | <input type="radio"/> Untagged            | <input type="checkbox"/> | <input type="checkbox"/> |
| 3     | GE3  | Hybrid | <input type="radio"/> Excluded            | <input type="radio"/> Tagged | <input checked="" type="radio"/> Untagged | <input type="checkbox"/> | <input type="checkbox"/> |
| 4     | GE4  | Trunk  | <input checked="" type="radio"/> Excluded | <input type="radio"/> Tagged | <input type="radio"/> Untagged            | <input type="checkbox"/> | <input type="checkbox"/> |

4. Add the Untagged GE2 and GE3 interfaces of Switch B to VLAN whose ports need links. Steps are similar to 2 and 3.

5. Add the Tagged GE1 interface of Switch A to VLAN10 and 20. Click the “VLAN Function > VLAN Configuration > VLAN Setting”, drop down the list to select VLAN10 and the Tagged member of GE1. Configure VLAN20 similarly.

### VLAN Configuration Table

VLAN VLAN0010

| Entry | Port | Mode  | Membership                     |   |                                | PVID                     | Forbidden                |
|-------|------|-------|--------------------------------|---|--------------------------------|--------------------------|--------------------------|
| 1     | GE1  | Trunk | <input type="radio"/> Excluded | <input checked="" type="radio"/> Tagged | <input type="radio"/> Untagged | <input type="checkbox"/> | <input type="checkbox"/> |

### VLAN Configuration Table

VLAN VLAN0020

| Entry | Port | Mode  | Membership                     |   |                                | PVID                     | Forbidden                |
|-------|------|-------|--------------------------------|---|--------------------------------|--------------------------|--------------------------|
| 1     | GE1  | Trunk | <input type="radio"/> Excluded | <input checked="" type="radio"/> Tagged | <input type="radio"/> Untagged | <input type="checkbox"/> | <input type="checkbox"/> |

6. Related protocol and VLAN. VLAN IDs are assigned according to the protocol (family) type and encapsulation format of the messages received by interfaces. Click the “VLAN Function > Protocol VLAN Configuration > Protocol Group Configuration” in the navigation tree to add 2 rules for protocol groups:

### Protocol Group Table

Showing All entries      Showing 1 to 2 of 2 entries

| <input type="checkbox"/> | Group ID | Frame Type  | Protocol Value |
|--------------------------|----------|-------------|----------------|
| <input type="checkbox"/> | 1        | Ethernet_II | 0x0800         |
| <input type="checkbox"/> | 2        | Ethernet_II | 0x86DD         |

7. Port, protocol group, and VLAN binding. Click the “VLAN Function > Protocol VLAN Group > Protocol Group Binding”, “Add” to bind GE2 and binding group ID1 with

VLAN10, and to bind GE3 and binding group ID2 with VLAN20:

### Group Binding Table

Showing  entries      Showing 1 to 2 of 2 entries     

| <input type="checkbox"/> | Port | Group ID | VLAN |
|--------------------------|------|----------|------|
| <input type="checkbox"/> | GE2  | 1        | 10   |
| <input type="checkbox"/> | GE3  | 2        | 20   |

## 6.4 Voice VLAN

Traditionally, ACL (Access Control List) will be applied to distinguish Voice Data and QoS (Quality of Service) will be used to ensure transmission quality, thus enhancing the priority. In order to simplify user configuration and facilitate voice flow management, Voice VLAN emerges. Enabled interface judges whether it is Voice Data flow or not according to the source MAC address field accessing the interface data flow. The message in the source MAC address is the Voice Data flow, which confirms to the OUI (Organizationally Unique Identifier) of the voice devices that are configured by the system. The interfaces receiving Voice Data flow will automatically transmit to Voice VLAN, thus simplifying user configuration and Voice Data management.

### OUI of Voice VLAN

OUI represents a MAC address field. Its address can be calculated based on the 48-bit MAC address and the corresponding bit of mask. The number of bits of ingress MAC address and matching OUI is determined by the length of the all-“1” -bit in the mask. For example, if the MAC address is 1-1-1 and the mask is FFFF-FF00-0000, the result of execution and calculation of MAC address and corresponding mask, namely OUI, will be 0001-0000-0000. As long as the first 24 bits of the ingress MAC address are matched with those of OUI, the enabled Voice VLAN interface identifies the data flow and the ingress device as the Voice Data flow and voice device respectively.

Voice VLAN is divided for user Voice Data flow. Voice VLANs are created to connect the interfaces linked with voice devices to transmit the Voice Data inside in a centralized way.

Voice Data and non-Voice Data often exist in the same network. Voice Data needs a higher priority than other business data during transmission to reduce the possible delay and packet loss.

1. Click the “VLAN Function > Voice VLAN > Function Configuration” in the navigation tree as follows.

|                                   |   |
|-----------------------------------|---|
| <b>State</b>                      | <input type="checkbox"/> Enable                           |
| <b>VLAN</b>                       | None <input type="text"/>                                 |
| <b>CoS / 802.1p<br/>Remarking</b> | <input type="checkbox"/> Enable<br>6 <input type="text"/> |
| <b>Aging Time</b>                 | 1440 <input type="text"/> Min (30 - 65536, default 1440)  |

### Port Setting Table

| <input type="checkbox"/> | Entry | Port | State    | Mode | QoS Policy   |
|--------------------------|-------|------|----------|------|--------------|
| <input type="checkbox"/> | 1     | GE1  | Disabled | Auto | Voice Packet |
| <input type="checkbox"/> | 2     | GE2  | Disabled | Auto | Voice Packet |
| <input type="checkbox"/> | 3     | GE3  | Disabled | Auto | Voice Packet |
| <input type="checkbox"/> | 4     | GE4  | Disabled | Auto | Voice Packet |
| <input type="checkbox"/> | 5     | GE5  | Disabled | Auto | Voice Packet |
| <input type="checkbox"/> | 6     | GE6  | Disabled | Auto | Voice Packet |
| <input type="checkbox"/> | 7     | GE7  | Disabled | Auto | Voice Packet |
| <input type="checkbox"/> | 8     | GE8  | Disabled | Auto | Voice Packet |

### Edit Port Setting

|                   |  |
|-------------------|--|
| <b>Port</b>       | GE1  |
| <b>State</b>      | <input type="checkbox"/> Enable  |
| <b>Mode</b>       | <input checked="" type="radio"/> Auto<br><input type="radio"/> Manual      |
| <b>QoS Policy</b> | <input checked="" type="radio"/> Voice Packet<br><input type="radio"/> All |

|                     |  |
|---------------------|--|
| Configuration Items | Description  |
| State               | Check and enable the Voice VLAN  |
| VLAN                | Specify the VLAN ID added ranging from 1 to 4,094, e.g. 1-3, 5, 7 and 9, with VLAN 1 by default. Other VLANs must be added in an untagged way to the port needing links. |
| CoS Remark          | Whether to redefine the Voice VLAN message priority or not   |
| Aging Time          | Table aging time   |
| Port                | Enabled Voice VLAN port  |
| Mode                | Voice VLAN port can be operated in auto mode and manual mode.  |
| QoS Strategy        | Select the message to be affected by QoS   |

- Click the “VLAN Function > Voice VLAN > Voice OUI Configuration” in the navigation tree to configure the address segment of OUI of Voice VLAN as follows:

#### Voice OUI Table

Showing All entries      Showing 1 to 8 of 8 entries     

| <input type="checkbox"/> | OUI      | Description |
|--------------------------|----------|-------------|
| <input type="checkbox"/> | 00:E0:BB | 3COM        |
| <input type="checkbox"/> | 00:03:6B | Cisco       |
| <input type="checkbox"/> | 00:E0:75 | Veritel     |
| <input type="checkbox"/> | 00:D0:1E | Pingtel     |
| <input type="checkbox"/> | 00:01:E3 | Siemens     |
| <input type="checkbox"/> | 00:60:B9 | NEC/Philips |
| <input type="checkbox"/> | 00:0F:E2 | H3C         |
| <input type="checkbox"/> | 00:09:6E | Avaya       |

  
   
   
   
   
1   
   

#### Add Voice OUI

|                    |  |
|--------------------|--|
| <b>OUI</b>         | <input type="text"/> : <input type="text"/> : <input type="text"/> |
| <b>Description</b> | <input type="text"/>   |

- Fill in corresponding configuration items.
- “Apply” and finish as follows.

### Voice OUI Table

Showing All entries      Showing 1 to 9 of 9 entries     

| <input type="checkbox"/> | OUI      | Description |
|--------------------------|----------|-------------|
| <input type="checkbox"/> | 00:E0:BB | 3COM        |
| <input type="checkbox"/> | 00:03:6B | Cisco       |
| <input type="checkbox"/> | 00:E0:75 | Veritel     |
| <input type="checkbox"/> | 00:D0:1E | Pingtel     |
| <input type="checkbox"/> | 00:01:E3 | Siemens     |
| <input type="checkbox"/> | 00:60:B9 | NEC/Philips |
| <input type="checkbox"/> | 00:0F:E2 | H3C         |
| <input type="checkbox"/> | 00:09:6E | Avaya       |
| <input type="checkbox"/> | 98:00:36 | H7650       |

For example, configure the Voice VLAN in manual mode so that the ports accessing IP telephony can ingress/egress the Voice VLAN and transmit voice flow within it. Create VLAN2 to operate Voice VLAN securely, which allows only Voice Data to flow through. IP telephony transmits Untagged voice flow to GE1, the ingress Trunk port. Users have to customize an OUI (0011-22 31-05e1) and configure the Voice VLAN networking diagram in automatic mode.

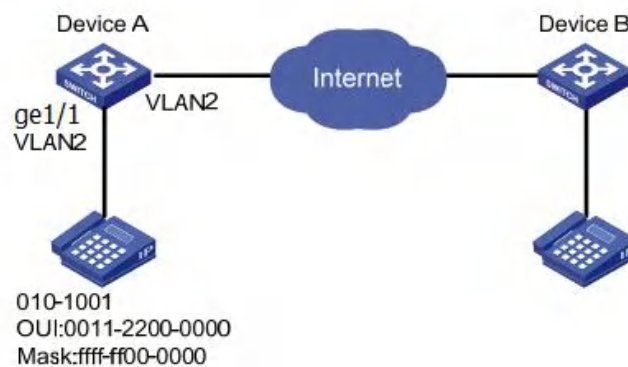

#### Instructions:

1. Create a VLAN to recognize the VLANs where employees belong. Click the “VLAN Function > VLAN Configuration > VLAN Creating” in the navigation tree to add VLAN2 to the VLAN list on the right. “Apply” and finish:

The screenshot shows a configuration window for VLANs. On the left, a green box labeled 'VLAN' is highlighted. In the center, there are two lists: 'Available VLAN' containing VLAN 3 through 10, and 'Created VLAN' containing VLAN 1 and 2. Navigation arrows are present between the lists. Below the lists is an 'Apply' button.

### VLAN Table

Showing  entries      Showing 1 to 2 of 2 entries

| <input type="radio"/> | VLAN | Name     | Type    | VLAN Interface State |
|-----------------------|------|----------|---------|----------------------|
| <input type="radio"/> | 1    | default  | Default | Disabled             |
| <input type="radio"/> | 2    | VLAN0002 | Static  | Disabled             |

- Configure the Ethernet interface GE1 of Switch A in Trunk mode. Click the “VLAN Function > VLAN Configuration > Port Configuration” in the navigation tree, “Modify” GE1 in Trunk mode:

### Port Setting Table

Q

| <input type="checkbox"/> | Entry | Port | Mode  | PVID | Accept Frame Type | Ingress Filtering | Uplink   | TPID   |
|--------------------------|-------|------|-------|------|-------------------|-------------------|----------|--------|
| <input type="checkbox"/> | 1     | GE1  | Trunk | 1    | All               | Enabled           | Disabled | 0x8100 |

- Click the “VLAN Function > Voice VLAN > Voice OUI Configuration” in the navigation tree to configure and add the range of OUI MAC address, and enter the first 24 bits of MAC address of voice device: 00:11:22. “Apply” and finish as follows:

### Voice OUI Table

Showing  entries      Showing 1 to 1 of 1 entries

| <input type="checkbox"/> | OUI      | Description |
|--------------------------|----------|-------------|
| <input type="checkbox"/> | 00:11:22 | aaa         |

- Enable the Voice VLAN of port GE1. Click the “VLAN Function > Voice VLAN > Function Configuration” in the navigation tree to enable the global configuration, select VLAN2. Select port GE1 in the configuration list, “Modify” and enable the auto mode. “Apply” and finish as follows:

|                                   |  |
|-----------------------------------|--|
| <b>State</b>                      | <input checked="" type="checkbox"/> Enable |
| <b>VLAN</b>                       | VLAN0002                                   |
| <b>CoS / 802.1p<br/>Remarking</b> | <input type="checkbox"/> Enable<br>6       |
| <b>Aging Time</b>                 | 1440 Min (30 - 65536, default 1440)        |

Apply

### Port Setting Table

| <input type="checkbox"/> | Entry | Port | State    | Mode | QoS Policy   |
|--------------------------|-------|------|----------|------|--------------|
| <input type="checkbox"/> | 1     | GE1  | Enabled  | Auto | Voice Packet |
| <input type="checkbox"/> | 2     | GE2  | Disabled | Auto | Voice Packet |

Note: With the auto mode enabled, ports will forward Voice VLAN messages even though there is no port in VLAN2.

## 6.5 MAC Configuration

Ethernet switches are mainly innovated to forward according to the purposes in the data link layer. That is, MAC address will transmit the messages to corresponding ports according to the purposes. MAC address forwarding table is a L2 table illustrating MAC addresses and forwarding ports, which is the basis of fast forwarding of L2 messages.

MAC address forwarding table contains following data:

- Destination MAC Address
- VLAN ID belonging to port
- Forwarding ingress No. of this device

There are two message forwarding types according to MAC address table info:

- Unicast mode: the switch directly transmits the messages from the table's egress when MAC address forwarding table contains corresponding entries with the destination MAC address.
- Broadcast mode: When the switch receives the messages with the destination address full of F-bits, or there is no entry corresponding to the MAC destination address in the forwarding table, the switch will forward the messages to all ports excluding the receiving port in this way.

### 6.5.1 MAC Configuration

Aging time and table info of MAC addresses can be configured and checked on this page. MAC address table needs constant updates to cater to network changes. It automatically generates entries that are limited by their lifetime (i.e. aging time). Those entries not refreshed after expiration will be deleted. The aging time of an entry will be recalculated if its record is refreshed before expiration.

Proper aging time helps to achieve the aging target of MAC address. Shortage of aging time may lead a large number of switches broadcast to discover the packets of destination MAC addresses, thus influencing the switch performance.

Aging too long can cause the switch to save outdated MAC address entries, thus exhausting the forwarding resources and failing to update the forwarding table based on network changes.

The switch may remove valid MAC address table entries due to too short aging time, thus reducing forwarding efficiency.

Generally speaking, the aging time recommended is 300 seconds by default.

Instructions for aging time setting:

1. Click the “MAC Address Table > Dynamic MAC Address Table” in the navigation tree to the configuration and display interface:

The screenshot shows the configuration and display interface for the Dynamic MAC Address Table. At the top, there is a configuration bar for 'Aging Time' with a text input field containing '300' and a label 'Sec (10 - 630, default 300)'. Below this is an 'Apply' button. The main section is titled 'Dynamic Address Table' and includes a search bar and pagination controls. A table displays the following entry:

| <input type="checkbox"/> | VLAN | MAC Address       | Port |
|--------------------------|------|-------------------|------|
| <input type="checkbox"/> | 1    | 50:3E:AA:B3:B7:BA | GE25 |

Below the table are 'Refresh' and 'Add Static Address' buttons. At the bottom right of the table area are navigation buttons: 'First', 'Previous', '1', 'Next', and 'Last'.

Interface data are as follows

| Configuration Items | Description                         |
|---------------------|-------------------------------------|
| MAC Aging Time      | Enter the aging time of MAC address |

2. Fill in corresponding configuration items.
3. “Apply” and finish.

MAC Table stores the MAC address, VLAN No., Ingress/Egress info, etc. that are learned by switches. When forwarding data, it will fast locate the device egress in accordance with the destination MAC address and VLAN No. query table of Ethernet frames.

Check the instructions for MAC address table:

4. Click the “System State > MAC Address Table” to check all MAC address info as follows:

### MAC Address Table

Showing All entries      Showing 1 to 2 of 2 entries     

| VLAN | MAC Address       | Type       | Port |
|------|-------------------|------------|------|
| 1    | 00:E0:4C:00:11:21 | Management | CPU  |
| 1    | 50:3E:AA:B3:B7:BA | Dynamic    | GE25 |

      
         1       

Interface data are as follows.

| Query Items | Description  |
|-------------|--|
| MAC         | Destination MAC Address  |
| VLAN        | VLAN ID belonging to MAC address   |
| Port        | Message egress corresponding to MAC address  |
| Type        | <p>Dynamic MAC Address refers to the entry which will age with the set aging time. Switches can add entries based on the learning mechanism of MAC address or manual creation.</p> <p>Static MAC address refers to the specified table which is manually configured and won't age.</p> <p>Management MAC address refers to the address at the management port.</p> |

## 6.5.2 Static MAC

Static table is manually configured by users and distributed to each interface board, which won't age.

Steps of establishing a static MAC address

1. Click the “MAC Address Table > Static MAC Address Table” as follows:

### Static Address Table

Showing All entries      Showing 1 to 1 of 1 entries     

| <input type="checkbox"/> | VLAN | MAC Address       | Port |
|--------------------------|------|-------------------|------|
| <input type="checkbox"/> | 1    | 00:00:11:11:22:22 | GE3  |

          
         1

### Add Static Address

|             |  |
|-------------|--|
| MAC Address | <input type="text" value="00:00:11:11:22:22"/> |
| VLAN        | <input type="text" value="10"/> × (1 - 4094)   |
| Port        | <input type="text" value="GE1"/>               |

Interface data are as follows.

| Configuration Items | Description  |
|---------------------|--|
| MAC                 | Required. Enter the new MAC address e.g.: HH:HH:HH:HH:HH:HH  |
| VLAN                | Required. Specify the VLAN ID  |
| Port                | Required. Select the interface type and enter the interface name<br>Description: it must be the member port of the configured VLANs. |

- Fill in corresponding configuration items.
- “Apply” and finish.

## 6.6 MSTP Configuration

Redundant links are often used for link backup and network reliability in the Ethernet switching network. However, such links will generate loops on the switching network, leading to broadcast storm, unstable MAC address list and other faults, thus worsening users’ communication quality, or even interrupting the communication. As a result, STP (Spanning Tree Protocol) appears.

Same with the development of other protocols, from the original STP defined in IEEE 802.1D, to RSTP (Rapid Spanning Tree Protocol) defined in IEEE 802.1W and to MSTP (Multiple Spanning Tree Protocol) defined in IEEE 802.1S, STP keeps upgrading.

MSTP is compatible with RSTP and STP while RSTP is compatible with STP. The contrast among these 3 protocols is shown in the table.

The contrast among 3 protocols

| STP  | Characteristic   | Application  |
|------|--|--|
| STP  | A tree rid of loops as the solution to broadcast storms and redundant backups.<br>It converges slowly. | All VLANs can be shared without discrimination in user or business flow. |
| RSTP | A tree rid of loops as the solution to broadcast storms and redundant backups.                         |  |

|      |   |   |
|------|---|---|
|      | It converges rapidly.   |   |
| MSTP | A tree rid of loops as the solution to broadcast storms and redundant backups.<br>It converges rapidly.<br>Spanning trees balance the load among VLANs. Flow of different VLANs will be forwarded subject to paths. | Distinguish the user and business flow for load sharing.<br>Different VLANs forward the flow through separate spanning trees. |

After STP is deployed, the following objectives can be achieved by calculating the loops with topology:

- Loop elimination: eliminate possible communication loops by blocking redundant links.
- Link backups: activate redundant links to restore network connectivity if the active path fails.

### 6.6.1 Global Configuration

Configure STP global parameters. In specific network environment, STP parameters of some devices have to be adjusted to achieve the best performance.

Instructions:

1. Click the “STP > Function Configuration” in the navigation tree as follows:

The screenshot shows the STP Function Configuration interface with the following settings:

- State:**  Enable
- Operation Mode:**
  - STP
  - RSTP
  - MSTP
- Path Cost:**
  - Long
  - Short
- BPDUs Handling:**
  - Filtering
  - Flooding
- Priority:** 32768 (0 - 61440, default 32768)
- Hello Time:** 2 Sec (1 - 10, default 2)
- Max Age:** 20 Sec (6 - 40, default 20)
- Forward Delay:** 15 Sec (4 - 30, default 15)
- Tx Hold Count:** 6 (1 - 10, default 6)
- Region Name:** 1C:2A:A3:02:BD:82
- Revision:** 0 (0 - 65535, default 0)
- Max Hop:** 20 (1 - 40, default 20)

Interface data are as follows.

| Configuration Items    | Description   |
|------------------------|---|
| Enabled                | It is checked by default to enable the spanning tree on behalf of switches.   |
| Running Mode           | 3 modes are available, namely STP, RSTP and MSTP.   |
| Path Cost Mode         | In Long mode and Short mode   |
| BPDU Forwarding Method | The method to handle the BPDU messages received by the device   |
| Priority               | Port priority   |
| Hello Time             | Intervals between Hello messages  |
| Max Age                | Max aging time  |
| Forward Delay          | Forward delay time  |
| Domain Name            | MST domain name. Switch master board sets the MAC address by default.<br>Together with the VLAN mapping table of MST domain and the revision level of MSTP, switch domain name will jointly determine the domain to which it belongs. |

2. Fill in corresponding configuration items.
3. “Apply” and finish.

## 6.6.2 Instance Configuration

A switching network is divided into multiple domains by MSTP, with independent spanning trees formed within each domain. Each Spanning Tree is called a MSTI (Multiple Spanning Tree Instance), and each domain is called a MST Region: Multiple Spanning Tree Region).



Description:

An instance is a group of VLANs that reduces communication cost and resource utilization rate. Each instance, independently calculated with topology, can balance the load. VLANs with the same topology can be mapped to a same instance, and they are forwarded according to the port state in corresponding MSTP instances.

In simple terms, mapped to the specified MST instance, one or more VLANs are distributed to a spanning tree at a time.

Instructions:

1. Click the “STP > Instance Configuration” in the navigation tree, “Modify” the selected spanning tree instances to be configured as follows:

### MST Instance Table

| MSTI | Priority | Bridge Identifier       | Designated Root Bridge | Root Port | Root Path Cost | Remaining Hop | VLAN   |
|------|----------|-------------------------|------------------------|-----------|----------------|---------------|--------|
| 0    | 32768    | 32768-1C:2A:A3:02:BD:82 | 0-00:00:00:00:00:00    | N/A       | 0              | 0             | 1-4094 |
| 1    | 32768    | 32768-1C:2A:A3:02:BD:82 | 0-00:00:00:00:00:00    | N/A       | 0              | 0             |        |
| 2    | 32768    | 32768-1C:2A:A3:02:BD:82 | 0-00:00:00:00:00:00    | N/A       | 0              | 0             |        |
| 3    | 32768    | 32768-1C:2A:A3:02:BD:82 | 0-00:00:00:00:00:00    | N/A       | 0              | 0             |        |
| 4    | 32768    | 32768-1C:2A:A3:02:BD:82 | 0-00:00:00:00:00:00    | N/A       | 0              | 0             |        |

### Edit MST Instance Setting

**MSTI** 1

**VLAN**

Available VLAN

- 1
- 2
- 3
- 4
- 5
- 6
- 7
- 8

**Selected VLAN**

**Priority**  (0 - 61440, default 32768)

**Bridge Identifier** 32768-1C:2A:A3:02:BD:82

**Designated Root Bridge** 0-00:00:00:00:00:00

**Root Port**

**Root Path Cost** 0

**Remaining Hop** 0

Apply
Close

Interface data are as follows.

| Configuration Items | Description  |
|---------------------|--|
| MSTI                | Instance No. of spanning trees ranges from 0 to 15   |
| VLAN                | VLAN No. mapped from instances   |
| Priority            | Set the priority of a multiple of 4,096 for the specified instance, ranging from 0 to 65,535 with 32,768 as default. |
| Bridge ID           | The bridge ID of the spanning tree instance corresponding to this device consists of the priority and MAC address.   |
| Root Bridge ID      | The elected instance root bridge ID consists of the priority and MAC address.  |
| Root Port           | The elected instance root port ID  |
| Root Cost           | Path cost to the root bridge   |

2. Fill in corresponding configuration items.
3. “Apply” and finish as follows.

**MST Instance Table**

| MSTI | Priority | Bridge Identifier       | Designated Root Bridge | Root Port | Root Path Cost | Remaining Hop | VLAN              |
|------|----------|-------------------------|------------------------|-----------|----------------|---------------|-------------------|
| 0    | 32768    | 32768-1C:2A:A3:02:BD:82 | 0-00:00:00:00:00:00    | N/A       | 0              | 0             | 1-9,11-19,21-4094 |
| 1    | 32768    | 32768-1C:2A:A3:02:BD:82 | 0-00:00:00:00:00:00    | N/A       | 0              | 0             | 10                |
| 2    | 32768    | 32768-1C:2A:A3:02:BD:82 | 0-00:00:00:00:00:00    | N/A       | 0              | 0             | 20                |
| 3    | 32768    | 32768-1C:2A:A3:02:BD:82 | 0-00:00:00:00:00:00    | N/A       | 0              | 0             |                   |

## 6.6.3 Instance Port Configuration

1. Click the “STP > Instance Port Configuration” in the navigation tree, check the port to be modified from the list of all ports of the device, “Modify” to enter the detailed configuration interface as follows:

**MST Port Setting Table**

MSTI 0

| Entry | Port | Path Cost | Priority | Port Role | Port State | Mode | Type     | Designated Bridge   | Designated Port ID | Designated Cost | Remaining Hop |
|-------|------|-----------|----------|-----------|------------|------|----------|---------------------|--------------------|-----------------|---------------|
| 1     | GE1  | 20000     | 128      | Disabled  | Disabled   | RSTP | Boundary | 0-00:00:00:00:00:00 | 128-1              | 0               | 20            |
| 2     | GE2  | 20000     | 128      | Disabled  | Disabled   | RSTP | Boundary | 0-00:00:00:00:00:00 | 128-2              | 0               | 20            |
| 3     | GE3  | 20000     | 128      | Disabled  | Disabled   | RSTP | Boundary | 0-00:00:00:00:00:00 | 128-3              | 0               | 20            |
| 4     | GE4  | 20000     | 128      | Disabled  | Forwarding | RSTP | Boundary | 0-00:00:00:00:00:00 | 128-4              | 0               | 20            |
| 5     | GE5  | 20000     | 128      | Disabled  | Disabled   | RSTP | Boundary | 0-00:00:00:00:00:00 | 128-5              | 0               | 20            |
| 6     | GE6  | 20000     | 128      | Disabled  | Disabled   | RSTP | Boundary | 0-00:00:00:00:00:00 | 128-6              | 0               | 20            |
| 7     | GE7  | 20000     | 128      | Disabled  | Disabled   | RSTP | Boundary | 0-00:00:00:00:00:00 | 128-7              | 0               | 20            |

**Edit MST Port Setting**

**MSTI** 0

**Port** GE1-GE2

**Path Cost**  (0 - 200000000) (0 = Auto)

**Priority** 128

**Port Role** Disabled

**Port State** Disabled

**Mode** RSTP

**Type** Boundary

**Designated Bridge** 0-00:00:00:00:00:00

**Designated Port ID** 128-1

**Designated Cost** 20000

**Remaining Hop** 20

Interface data are as follows.

| Configuration Items | Description  |
|---------------------|--|
| MSTI                | Select the instance for configuration through the drop-down box in the |

|            |   |
|------------|---|
|            | upper left.   |
| Port       | Select the port to be configured by users   |
| Path Cost  | Enter the path cost value of the interface Use IEEE 802.1t Standard with the value ranging from 0 to 200,000,000  |
| Priority   | Select the port priority with smaller value representing higher priority.<br>Interface priority affects the role of the interface on the specified MSTI. On different MSTI, users can configure the priorities for a same interface. As a result, flow of different VLANs can be forwarded along physical links to achieve VLAN load sharing.<br>Description: MSTP will recalculate the interface role and migrate its state when its priority changes. |
| Port Role  | 3 types of root ports, namely specified port, backup port and disabled port.  |
| Port State | Including 3 states, namely Discarding, Forwarding and Disabled  |
| Mode       | Current STP mode  |
| Type       | The port types in the instance contain boundary and internal ports  |

2. Fill in corresponding configuration items.
3. “Apply” and finish.

## 6.6.4 Port Configuration

In specific network environment, STP parameters of some devices need to be adjusted for the best performance.

1. Click the “STP Function > Port Configuration” in the navigation tree, select the port and “Modify” to configure its attributes:

Port Setting Table

| Entry | Port | State   | Path Cost | Priority | BPDU Filter | BPDU Guard | Operational Edge | Operational Point-to-Point | Port Role | Port State | Designated Bridge   | Designated Port ID | Designated Cost |
|-------|------|---------|-----------|----------|-------------|------------|------------------|----------------------------|-----------|------------|---------------------|--------------------|-----------------|
| 1     | GE1  | Enabled | 20000     | 128      | Disabled    | Disabled   | Disabled         | Disabled                   | Disabled  | Disabled   | 0-00:00:00:00:00:00 | 128-1              | 20000           |
| 2     | GE2  | Enabled | 20000     | 128      | Disabled    | Disabled   | Disabled         | Disabled                   | Disabled  | Disabled   | 0-00:00:00:00:00:00 | 128-2              | 20000           |
| 3     | GE3  | Enabled | 20000     | 128      | Disabled    | Disabled   | Disabled         | Disabled                   | Disabled  | Disabled   | 0-00:00:00:00:00:00 | 128-3              | 20000           |
| 4     | GE4  | Enabled | 20000     | 128      | Disabled    | Disabled   | Disabled         | Enabled                    | Disabled  | Forwarding | 0-00:00:00:00:00:00 | 128-4              | 20000           |
| 5     | GE5  | Enabled | 20000     | 128      | Disabled    | Disabled   | Disabled         | Disabled                   | Disabled  | Disabled   | 0-00:00:00:00:00:00 | 128-5              | 20000           |
| 6     | GE6  | Enabled | 20000     | 128      | Disabled    | Disabled   | Disabled         | Disabled                   | Disabled  | Disabled   | 0-00:00:00:00:00:00 | 128-6              | 20000           |
| 7     | GE7  | Enabled | 20000     | 128      | Disabled    | Disabled   | Disabled         | Disabled                   | Disabled  | Disabled   | 0-00:00:00:00:00:00 | 128-7              | 20000           |
| 8     | GE8  | Enabled | 20000     | 128      | Disabled    | Disabled   | Disabled         | Disabled                   | Disabled  | Disabled   | 0-00:00:00:00:00:00 | 128-8              | 20000           |

### Edit Port Setting

|                                   |  |
|-----------------------------------|--|
| <b>Port</b>                       | GE1  |
| <b>State</b>                      | <input checked="" type="checkbox"/> Enable   |
| <b>Path Cost</b>                  | <input type="text" value="0"/> (0 - 200000000) (0 = Auto)  |
| <b>Priority</b>                   | 128  |
| <b>Edge Port</b>                  | <input type="checkbox"/> Enable  |
| <b>BPDU Filter</b>                | <input type="checkbox"/> Enable  |
| <b>BPDU Guard</b>                 | <input type="checkbox"/> Enable  |
| <b>Point-to-Point</b>             | <input checked="" type="radio"/> Auto<br><input type="radio"/> Enable<br><input type="radio"/> Disable |
| <b>Port State</b>                 | Disabled   |
| <b>Designated Bridge</b>          | 0-00:00:00:00:00:00  |
| <b>Designated Port ID</b>         | 128-1  |
| <b>Designated Cost</b>            | 20000  |
| <b>Operational Edge</b>           | False  |
| <b>Operational Point-to-Point</b> | False  |

Interface data are as follows.

| Configuration Items | Description  |
|---------------------|--|
| Port                | The port No. to configure attributes   |
| State               | Enable STP or not  |
| Edge Port           | Rather than another switch or network segment, the edge port should be connected directly to user terminals. It can quickly transit to the forward state since topology changes create no loops. An edge port under configuration can be quickly transitioned to forward state by STP. To achieve this, it is recommended that Ethernet ports connected directly to user terminals should be configured as edge ports. |
| BPDU Filter         | Enable BPDU Filter or not  |
| BPDU Guard          | Enable BPDU Guard or not. Unchecked by default. If BPDU Guard is enabled, the device will shut down the interfaces receiving BPDU and notify the NMS. Such interfaces can only be restored manually by network administrators.   |
| Point-to-Point      | Select enabled, shutdown, and auto modes.<br>Auto mode: it indicates the connect state between the default auto inspection and point-to-point links.<br>Enabled mode: it indicates the specific port is connected to the   |

|  |  |
|--|--|
|  | <p>point-to-point links.</p> <p>Shutdown mode: it indicates the specific port fails to connect the point-to-point links.</p> |
|--|--|

2. Fill in corresponding configuration items.
3. “Apply” and finish.

Example of MSTP function configuration:

Switch A, B, C and D all run MSTP which introduces instances to share the load of VLAN10 and 20. MSTP can set up the VLAN mapping table to associate VLANs with spanning tree instances, and to map VLAN10 from instance 1 and VLAN20 from instance 2.

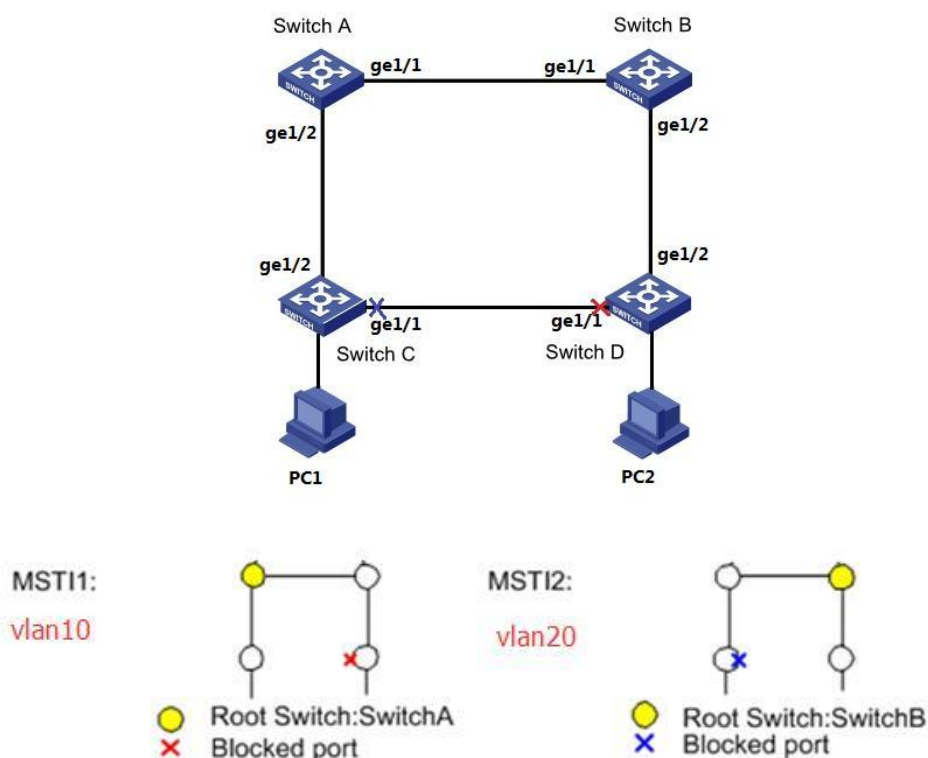

Instructions:

1. Switch A, B, C and D create VLAN10 and 20 to configure the L2 forwarding function of the devices on the Ring. Click the “VLAN Function > VLAN Configuration > VLAN Creating” in the navigation tree, fill in the corresponding configurations. “Apply” and finish as follows.

VLAN

Available VLAN

- VLAN 2
- VLAN 3
- VLAN 4
- VLAN 5
- VLAN 6
- VLAN 7
- VLAN 8
- VLAN 9

>

<

Created VLAN

- VLAN 1
- VLAN 10
- VLAN 20

### VLAN Table

Showing All entries      Showing 1 to 3 of 3 entries     

| VLAN                     | Name     | Type    | VLAN Interface State |
|--------------------------|----------|---------|----------------------|
| <input type="radio"/> 1  | default  | Default | Disabled             |
| <input type="radio"/> 10 | VLAN0010 | Static  | Disabled             |
| <input type="radio"/> 20 | VLAN0020 | Static  | Disabled             |

- VLANs are added to the switch ports ingress loops. Click the “VLAN Function > VLAN Configuration > Member Configuration” in the navigation tree, select the ring port to be configured, move VLAN10 and 20 to the right box and mark them with “Tagged”. “Apply” and finish:

### Edit Port Setting

Port

GE1

Mode

Trunk

Membership

- 10
- 20

>

<

1UP

Forbidden  
 Excluded  
 Tagged  
 Untagged  
 PVID

- Click the “STP > Function Configuration” in the navigation tree, and choose MSTP mode as follows:

|                       |  |
|-----------------------|--|
| <b>State</b>          | <input checked="" type="checkbox"/> Enable   |
| <b>Operation Mode</b> | <input type="radio"/> STP<br><input type="radio"/> RSTP<br><input checked="" type="radio"/> MSTP |
| <b>Path Cost</b>      | <input checked="" type="radio"/> Long<br><input type="radio"/> Short                             |
| <b>BPDU Handling</b>  | <input type="radio"/> Filtering<br><input checked="" type="radio"/> Flooding                     |
| <b>Priority</b>       | <input type="text" value="32768"/> (0 - 61440, default 32768)                                    |
| <b>Hello Time</b>     | <input type="text" value="2"/> Sec (1 - 10, default 2)   |
| <b>Max Age</b>        | <input type="text" value="20"/> Sec (6 - 40, default 20)   |
| <b>Forward Delay</b>  | <input type="text" value="15"/> Sec (4 - 30, default 15)   |
| <b>Tx Hold Count</b>  | <input type="text" value="6"/> (1 - 10, default 6)   |
| <b>Region Name</b>    | <input type="text" value="1C:2A:A3:02:BD:82"/>   |
| <b>Revision</b>       | <input type="text" value="0"/> (0 - 65535, default 0)  |
| <b>Max Hop</b>        | <input type="text" value="20"/> (1 - 40, default 20)   |

- Configure the VLAN mapping between instance MSTI1 and MSTI2. Click the “STP > Instance Configuration” to fill in corresponding parameters, and “Add” them as follows:

**MST Instance Table**

| MSTI | Priority | Bridge Identifier       | Designated Root Bridge | Root Port | Root Path Cost | Remaining Hop | VLAN              |
|------|----------|-------------------------|------------------------|-----------|----------------|---------------|-------------------|
| 0    | 32768    | 32768-1C:2A:A3:02:BD:82 | 0-00:00:00:00:00:00    | N/A       | 0              | 0             | 1-9,11-19,21-4094 |
| 1    | 32768    | 32768-1C:2A:A3:02:BD:82 | 0-00:00:00:00:00:00    | N/A       | 0              | 0             | 10                |
| 2    | 32768    | 32768-1C:2A:A3:02:BD:82 | 0-00:00:00:00:00:00    | N/A       | 0              | 0             | 20                |
| 3    | 32768    | 32768-1C:2A:A3:02:BD:82 | 0-00:00:00:00:00:00    | N/A       | 0              | 0             |                   |

Note:

Set the priority of MSTI1 to 0 and MSTI2 to 4,096 before configuring Switch A.

Set the priority of MSTI1 to 4,096 and MSTI2 to 0 before configuring Switch B.

The priority must be a multiple of 4,096.

- Switch B serves as the root bridge of MSTI2 and the backup root bridge of MSTI1 in the domain. Please refer to 5 for instructions.
- The tree-shaped network will eliminate loops.

## 6.7 IGMP Snooping Configuration

IGMP Snooping (Internet Group Management Protocol Snooping) is a constraint mechanism on L2 devices to manage and control multicast groups.

By analyzing the IGMP messages received, L2 devices establish a mapping between ports and MAC multicast addresses and forward the multicast data accordingly.

As shown below, multicast data are transmitted on L2 without IGMP snooping. When IGMP snooping runs, known multicast group data are transmitted to specified receivers while unknown multicast data are still on Layer 2.

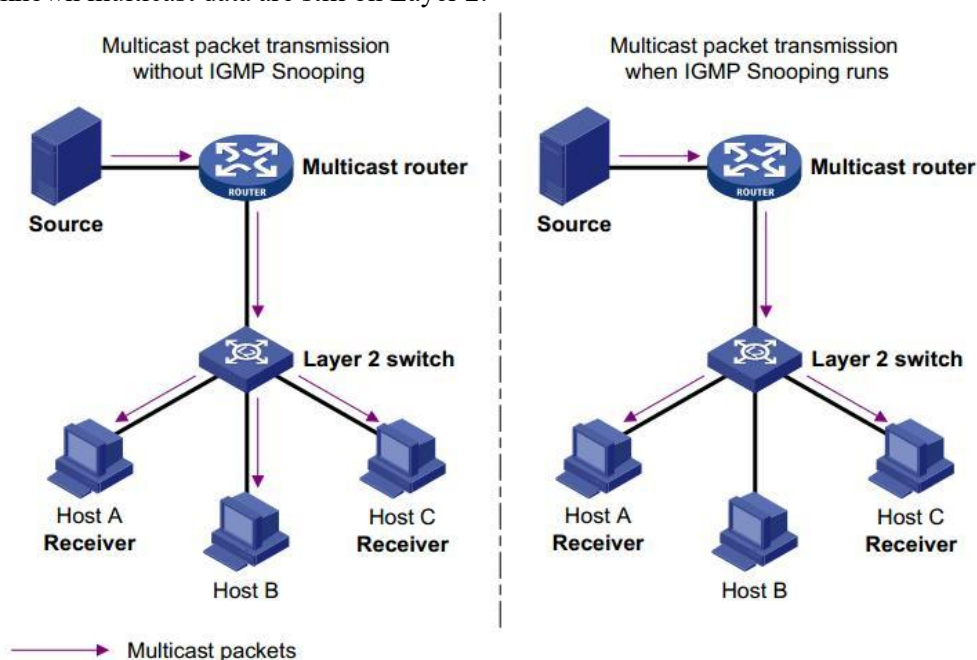

### 6.7.1 IGMP Snooping Configuration

IGMP Snooping is on the L2 switch between the multicast routers and the user hosts, applicable to deploy IPv4 networks. It is configured in a VLAN to snoop the IGMP/MLD messages transmitted between routers and hosts, and to establish a L2 forwarding table for multicast data, so as to manage and control the multicast data forwarding in L2 network.

Global IGMP Snooping function should be enabled since it is disabled by default.

Instructions:

1. Click the "Multicast > IGMP Snooping > Function Configuration", select the VLAN to be configured from the created VLAN info, and "Modify" the details as follows:

|                           |   |
|---------------------------|---|
| <b>State</b>              | <input type="checkbox"/> Enable   |
| <b>Version</b>            | <input checked="" type="radio"/> IGMPv2<br><input type="radio"/> IGMPv3 |
| <b>Report Suppression</b> | <input checked="" type="checkbox"/> Enable                              |

Apply

### VLAN Setting Table

| <input type="checkbox"/> | VLAN | Operational Status | Router Port Auto Learn | Query Robustness | Query Interval | Query Max Response Interval | Last Member Query Counter | Last Member Query Interval | Immediate Leave |
|--------------------------|------|--------------------|------------------------|------------------|----------------|-----------------------------|---------------------------|----------------------------|-----------------|
| <input type="checkbox"/> | 1    | Disabled           | Enabled                | 2                | 125            | 10                          | 2                         | 1                          | Disabled        |
| <input type="checkbox"/> | 10   | Disabled           | Enabled                | 2                | 125            | 10                          | 2                         | 1                          | Disabled        |
| <input type="checkbox"/> | 20   | Disabled           | Enabled                | 2                | 125            | 10                          | 2                         | 1                          | Disabled        |

Edit

### Edit VLAN Setting

|                                    |  |
|------------------------------------|--|
| <b>VLAN</b>                        | 20   |
| <b>State</b>                       | <input type="checkbox"/> Enable                                |
| <b>Router Port Auto Learn</b>      | <input checked="" type="checkbox"/> Enable                     |
| <b>Immediate leave</b>             | <input type="checkbox"/> Enable                                |
| <b>Query Robustness</b>            | <input type="text" value="2"/> (1 - 7, default 2)              |
| <b>Query Interval</b>              | <input type="text" value="125"/> Sec (30 - 18000, default 125) |
| <b>Query Max Response Interval</b> | <input type="text" value="10"/> Sec (5 - 20, default 10)       |
| <b>Last Member Query Counter</b>   | <input type="text" value="2"/> (1 - 7, default 2)              |
| <b>Last Member Query Interval</b>  | <input type="text" value="1"/> Sec (1 - 25, default 1)         |
| <b>Operational Status</b>          |  |
| <b>Status</b>                      | Disabled   |
| <b>Query Robustness</b>            | 2  |
| <b>Query Interval</b>              | 125 (Sec)  |
| <b>Query Max Response Interval</b> | 10 (Sec)   |
| <b>Last Member Query Counter</b>   | 2  |
| <b>Last Member Query Interval</b>  | 1 (Sec)  |

Apply

Close

Interface data are as follows.

| Configuration Items  | Description                                      |
|----------------------|--|
| VLAN                 | VLAN ID to be configured                         |
| State                | Enable or disable the IGMP Snooping in this VLAN |
| Routed Port Learning |  |

|   |  |
|---|--|
| Fast Leave                              |  |
| Number of Query                         | Max number of multicast queries                            |
| Query Interval                          | The interval between message queries                       |
| Max Response Time of Queries            | Timeout (over the max response time) of a query message    |
| Number of Queries for a Specified Group | Max number of queries for a specified group                |
| Query Intervals for a Specified Group   | The interval between message queries for a specified group |

2. Fill in corresponding configuration items.
3. “Apply” and finish.

## 6.7.2 Static Multicast

According to the previous request mode of multicast, the multicast router will copy and forward data to each VLAN containing receivers when users in different VLANs request the same multicast group, which wastes a great deal of bandwidth. IGMP Snooping configures multicast VLAN by connecting the different users of switch ports to a same multicast VLAN to receive multicast data. In this way, multicast flow can only be transmitted within a multicast VLAN, thus saving bandwidth. In addition, security and bandwidth are guaranteed because multicast VLANs are completely isolated from user VLANs.

Instructions

1. Click the “Multicast > Basic Function > Static Multicast Configuration”, “Add” a new static multicast item, and “Modify” the existing ones as follows:

### Group Address Table

IP Version

Showing  entries      Showing 0 to 0 of 0 entries     

| <input type="checkbox"/> | VLAN | Group Address | Member | Type | Life (Sec) |
|--------------------------|------|---------------|--------|------|------------|
| 0 results found.         |      |               |        |      |            |

### Add Group Address

Interface data are as follows.

| Configuration Items | Description   |
|---------------------|---|
| VLAN                | VLAN ID to which the multicast group belongs. Drop down to select an existing VLAN. |
| IP Version          | Whether v4 or v6 is the version of multicast IP address                             |
| Multicast Address   | Enter the multicast address   |
| Member              | Add multicast member(s)   |

- Fill in corresponding configuration items.
- “Apply” and finish as follows.

### Group Address Table

| <input type="checkbox"/> | VLAN | Group Address               | Member  | Type   | Life (Sec) |
|--------------------------|------|-----------------------------|---------|--------|------------|
| <input type="checkbox"/> | 1    | <a href="#">224.1.1.111</a> | GE1-GE8 | Static |            |

## 6.8 DHCP Snooping Configuration

For sake of security, the network administrator may need to record the IP address of a user surfing the Internet and to confirm the correspondence between the IP address obtained from

DHCP Server and the host's MAC address.

Switch can record the user's IP address through the secure DHCP relay at the network layer. Switch can monitor DHCP messages and record the user's IP address through DHCP Snooping at the data link layer. In addition, private DHCP Server in the network may lead to wrong IP address for the user. To ensure that users obtain IP addresses through legal DHCP Server, the DHCP Snooping security mechanism divides the ports into Trust Port and Untrust Port.

Trust Port directly or indirectly connects legal DHCP Server. It forwards the DHCP messages received to ensure the correct IP address for DHCP Client. Untrust Port connects illegal DHCP Server. DHCPACK and DHCPOFFER messages received from the DHCP Server on the Untrust Port will be discarded to prevent incorrect IP addresses.

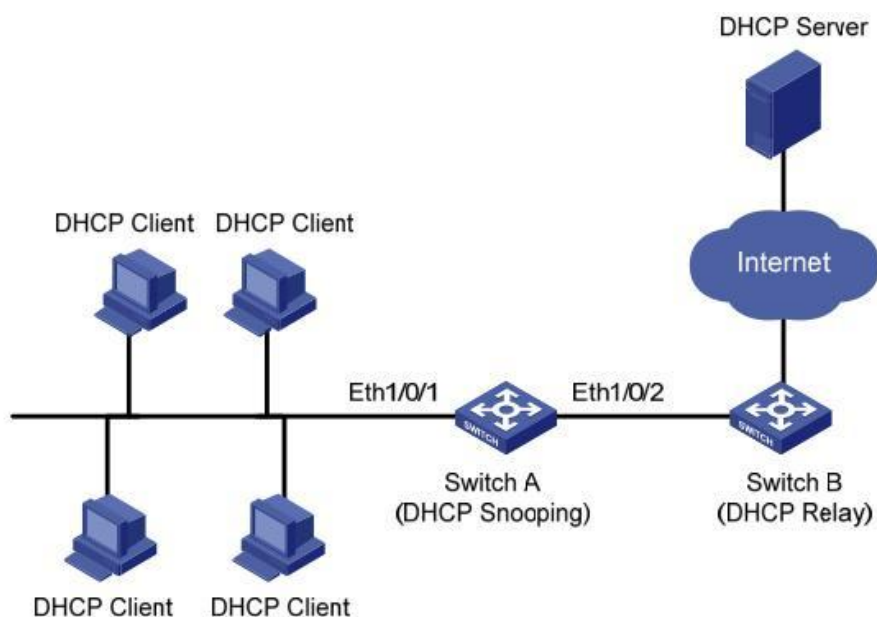

Typical Networking of DHCP Snooping

The following methods are used to obtain the IP address and user MAC address from DHCP Server:

- Snooping the DHCPREQUEST message
- Snooping the DHCPACK message

## 6.8.1 DHCP Snooping Global Configuration

Enable DHCP Snooping

Instructions:

1. Click the “Security > DHCP Snooping > Function Configuration”. DHCP Snooping interface is divided into global configuration and port configuration. Select the port to be modified in the port configuration and “Modify” the details as follows:

|              |   |   |
|--------------|---|---|
| <b>State</b> | <input type="checkbox"/> Enable   |   |
| <b>VLAN</b>  | Available VLAN  | Selected VLAN   |
|              | <div style="border: 1px solid #ccc; padding: 2px;">           VLAN 1<br/>           VLAN 10<br/>           VLAN 20         </div> | <div style="border: 1px solid #ccc; padding: 2px; width: 100px; height: 50px;"></div> |

Apply

### Port Setting Table

| <input type="checkbox"/> | Entry | Port | Trust    | Verify Chaddr | Rate Limit |
|--------------------------|-------|------|----------|---------------|------------|
| <input type="checkbox"/> | 1     | GE1  | Disabled | Disabled      | Unlimited  |
| <input type="checkbox"/> | 2     | GE2  | Disabled | Disabled      | Unlimited  |
| <input type="checkbox"/> | 3     | GE3  | Disabled | Disabled      | Unlimited  |
| <input type="checkbox"/> | 4     | GE4  | Disabled | Disabled      | Unlimited  |
| <input type="checkbox"/> | 5     | GE5  | Disabled | Disabled      | Unlimited  |
| <input type="checkbox"/> | 6     | GE6  | Disabled | Disabled      | Unlimited  |
| <input type="checkbox"/> | 7     | GE7  | Disabled | Disabled      | Unlimited  |

### Edit Port Setting

|                      |   |
|----------------------|---|
| <b>Port</b>          | GE1-GE2   |
| <b>Trust</b>         | <input type="checkbox"/> Enable   |
| <b>Verify Chaddr</b> | <input type="checkbox"/> Enable   |
| <b>Rate Limit</b>    | <input type="text" value="0"/> pps (1 - 300, default 0), 0 is Unlimited |

Apply

Close

Interface data are as follows.

| Configuration Items       | Description  |
|---------------------------|--|
| State                     | Enable and disable the DHCP Snooping                               |
| VLAN                      | Valid VLAN No. of DHCP Snooping                                    |
| Port                      | Configure the port No. of DHCP Snooping                            |
| Trust                     | Whether the port is a Trust Port                                   |
| Client Address Inspection | Whether the consistency inspection for Client addresses is enabled |
| Rate Limit                | Whether the port enables rate limit and configures the value       |

2. Fill in corresponding configuration items.

3. “Apply” and finish as follows.

### Port Setting Table

| <input type="checkbox"/> | Entry | Port | Trust    | Verify Chaddr | Rate Limit |
|--------------------------|-------|------|----------|---------------|------------|
| <input type="checkbox"/> | 1     | GE1  | Enabled  | Enabled       | 100        |
| <input type="checkbox"/> | 2     | GE2  | Enabled  | Enabled       | 100        |
| <input type="checkbox"/> | 3     | GE3  | Disabled | Disabled      | Unlimited  |
| <input type="checkbox"/> | 4     | GE4  | Disabled | Disabled      | Unlimited  |

## 6.8.2 Static Binding

In DHCP network, users (non-DHCP users) obtaining IP addresses statically may attack the network by imitating DHCP Server, constructing DHCP Request message, etc. Legal DHCP users may suffer from security risks when using the network normally.

Enabling the static MAC entries based on the interface generated by DHCP Snooping binding table can prevent such attacks. The device then, based on the DHCP Snooping binding table corresponding to all DHCP users, automatically executes the command to generate static MAC entries and disable the interface’s learning ability of dynamic entries. Only messages that match the source MAC and static MAC entries can flow through the interface. Therefore, for non-DHCP users, only the messages of static MAC entries that are manually configured by the administrators can flow through, while others will be discarded.

Instructions:

1. Click the “Security > IP Source Guard > IMPV Binding”, “Add” a new binding group of IP-MAC-Port-VLAN as follows:

### IP-MAC-Port-VLAN Binding Table

Showing  entries      Showing 0 to 0 of 0 entries

| <input type="checkbox"/> | Port | VLAN | MAC Address | IP Address | Binding | Type | Lease Time |
|--------------------------|------|------|-------------|------------|---------|------|------------|
| 0 results found.         |      |      |             |            |         |      |            |

### Add IP-MAC-Port-VLAN Binding

|             |   |
|-------------|---|
| Port        | GE1   |
| VLAN        | (1 - 4094)  |
| Binding     | <input checked="" type="radio"/> IP-MAC-Port-VLAN<br><input type="radio"/> IP-Port-VLAN |
| MAC Address |   |
| IP Address  | / 255.255.255.255   |

Apply Close

Interface data are as follows.

| Configuration Items | Description                                   |
|---------------------|---|
| Port                | The port No. of binding group                 |
| VLAN                | VLAN ID bound                                 |
| Binding             | Select the binding relation from IPMV and IPV |
| MAC Address         | MAC address bound                             |
| IP Address          | IP address bound                              |

- Fill in corresponding configuration items.
- “Apply” and finish as follows.

### IP-MAC-Port-VLAN Binding Table

Showing All entries Showing 1 to 1 of 1 entries

| Port | VLAN | MAC Address       | IP Address                      | Binding          | Type   | Lease Time |
|------|------|-------------------|---------------------------------|------------------|--------|------------|
| GE1  | 1    | 00:00:11:11:22:22 | 192.168.1.123 / 255.255.255.255 | IP-MAC-Port-VLAN | Static | N/A        |

Add Edit Delete First Previous 1 Next Last

## 6.8.3 DHCP Snooping Port Configuration

Private DHCP Servers in the network may lead to wrong IP addresses obtained by users. DHCP Snooping security mechanism based on PS7024 Ethernet switch divides the ports into Trust Port and Untrust Port in order to provide the IP addresses through legal DHCP Servers.

- Trust Port directly or indirectly connects legal DHCP Server. It ensures the correct IP address for DHCP Client by forwarding the DHCP messages received.
- Untrust Port connects illegal DHCP servers. DHCP ACK and DHCP OFFER messages responded by DHCP Server on untrusted ports will be discarded to prevent incorrect IP addresses.

Option 82 is the Relay Agent Information Option in DHCP messages, which records the location of DHCP Client. When the DHCP relay (or DHCP Snooping device) receives the Request message sent from DHCP Client to DHCP Server, administrators can add the Option 82 to locate the DHCP Client and control the security, cost, etc. More flexible approaches to address allocation are created by the servers supporting Option 82 in line with the IP addresses and other parameters allocation policies.

Up to 255 sub-options are contained in the Option 82. At least one sub-option should be defined if Option 82 is defined. The current device supports 2 sub-options: Circuit ID Sub-option and Remote ID Sub-option

Manufacturers usually fill options as needed since RFC 3046 fails to uniform the Option 82 options. As the DHCP relay device, Ethernet switch supports the extended padding formats for Option 82 sub-options and the padding defaults are as follows:

Sub-option 1: VLAN No. and port index (port physical number minus 1) of the port receiving the Request message sent by DHCP Client.

Sub-option 2: bridge MAC address of DHCP relay device receiving the DHCP Client Request message.

Sub-option 1: VLAN No. and port index (port physical number minus 1) of the port receiving the Request message sent by DHCP Client as follows.

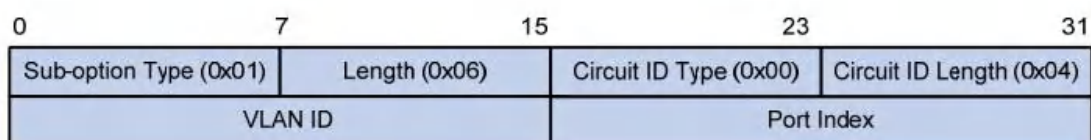

Sub-option 2: bridge MAC address of DHCP relay device receiving the DHCPREQUEST message of DHCP Client.

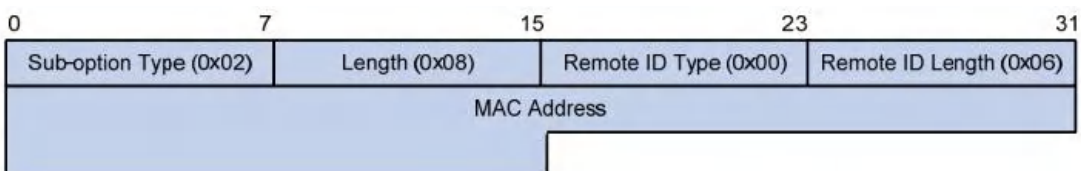

#### DHCP Relay Supporting Mechanism of Option 82

The processes of DHCP Client acquiring IP address from DHCP Server through DHCP relay is basically the same as that directly from DHCP Server. Steps of discovery, provision, selection, and validation are essential. The supporting mechanism of DHCP relay is introduced as follows:

(1) DHCP relay will check the Option 82 in the DHCPREQUEST message received and handle it accordingly.

- For existing Option 82 messages, DHCP relay will process according to the configuration policies (discarding, replacing with relay Option 82, or maintaining original Option 82), and then forward to DHCP Server.
- For messages without Option 82, DHCP relay will add and forward the new messages to DHCP Server.

(2) DHCP relay will peel off Option 82 from the response message received from DHCP Server, and then forward the message with DHCP configuration info to DHCP Client.

**Description:**

DHCP Client transmits a DHCPDISCOVERY message and a DHCPREQUEST message. DHCP relay will add Option 82 to both messages due to different processing mechanisms of DHCP Servers of manufacturers for Request message. Some devices handle Option 82 in the DHCPDISCOVERY message, while others handle it in the DHCPREQUEST message.

A switch configured with DHCP Snooping and Option 82 functions receives DHCPREQUEST messages with Option 82 sent by DHCP Clients. DHCP Snooping takes different processing mechanisms according to different configuration processing strategies and sub-option contents.

**Instructions:**

1. Click the “Security > DHCP Snooping > Option 82 Function Configuration”. Global and port configurations are contained. Select the port to be configured and “Modify” the details as follows:

Remote ID
 User Defined

**Operational Status**

Remote ID 1c:2a:a3:02:bd:82 (Switch Mac in Byte Order)

**Port Setting Table**

| <input type="checkbox"/> | Entry | Port | State    | Allow Untrust |
|--------------------------|-------|------|----------|---------------|
| <input type="checkbox"/> | 1     | GE1  | Disabled | Drop          |
| <input type="checkbox"/> | 2     | GE2  | Disabled | Drop          |
| <input type="checkbox"/> | 3     | GE3  | Disabled | Drop          |
| <input type="checkbox"/> | 4     | GE4  | Disabled | Drop          |
| <input type="checkbox"/> | 5     | GE5  | Disabled | Drop          |
| <input type="checkbox"/> | 6     | GE6  | Disabled | Drop          |
| <input type="checkbox"/> | 7     | GE7  | Disabled | Drop          |

**Edit Port Setting**

Port GE1-GE2

State  Enable

Allow Untrust
 Keep  
 Drop  
 Replace

Interface data are as follows.

| Configuration Items | Description   |
|---------------------|---|
| Remote ID           | Fill in the Remote ID fields in Option 82 (such as user-defined abcd)   |
| Port                | Whether the port No. of Option 82 is enabled  |
| Untrust Port Access | Untrust Port processes messages with Option 82 enabled:<br>Maintaining: leave Option 82 in the message unchanged and forward it<br>Discarding: discard the message<br>Replacing: replace and forward the Option 82 field in the message according to the Circuit ID configuration |

Description:

Option 82 field independently configures Circuit ID or Remote ID sub-options.

It can be configured individually or simultaneously in no particular order.

DHCP Option 82 must be configured in the user bar, otherwise DHCP messages sent to DHCP Server won't carry Option 82.

When receiving the DHCP response message from DHCP Server, the message containing Option 82 will be forwarded after deleting the field, or forwarded directly if the message contains no Option 82.

2. Fill in corresponding configuration items.
3. "Apply" and finish as follows.

The screenshot shows a configuration window for Remote ID. At the top, there is a checkbox labeled "User Defined" which is checked. Below it is a text input field containing "aaaaa". Underneath the input field is a green bar labeled "Operational Status". Below the status bar, there is a summary row with "Remote ID" and "aaaaa". At the bottom of the window is an "Apply" button.

### Port Setting Table

| <input type="checkbox"/> | Entry | Port | State    | Allow Untrust |
|--------------------------|-------|------|----------|---------------|
| <input type="checkbox"/> | 1     | GE1  | Enabled  | Replace       |
| <input type="checkbox"/> | 2     | GE2  | Enabled  | Replace       |
| <input type="checkbox"/> | 3     | GE3  | Enabled  | Replace       |
| <input type="checkbox"/> | 4     | GE4  | Disabled | Drop          |
| <input type="checkbox"/> | 5     | GE5  | Disabled | Drop          |

Illustration of DHCP Snooping Typical Configuration

1. DHCP Snooping supports Option 82

As shown below, Switch port GE1-5 is connected to DHCP Server, and ports GE1-1, 2

and 3 are connected to DHCP Client A, B and C respectively.

Enable the DHCP Snooping on the switch.

Set the GE1-5 as the trust port of DHCP Snooping.

Enable the Option 82 supporting function on the switch. For GE1-3 message flowing through the port, fill in the Option 82 according to the default configuration of Circuit ID and Remote ID.

**Network Diagram**

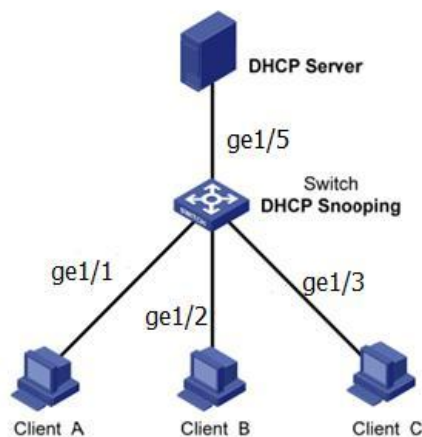

**Configure DHCP snooping to support Option 82**

Instructions:

2. Enable the DHCP Snooping of switch. Click the “DHCP Snooping Configuration > Function Configuration” in the navigation tree to enable the function as follows:

**State**  Enable

**VLAN**

|                |                              |
|----------------|------------------------------|
| Available VLAN | Selected VLAN                |
|                | VLAN 1<br>VLAN 10<br>VLAN 20 |

3. Set the GE1-5 as the trust port of DHCP Snooping, fill in corresponding configurations and “Modify” as follows:

**Port Setting Table**

| Entry                    | Port | Trust | Verify Chaddr | Rate Limit |           |
|--------------------------|------|-------|---------------|------------|-----------|
| <input type="checkbox"/> | 1    | GE1   | Disabled      | Disabled   | Unlimited |
| <input type="checkbox"/> | 2    | GE2   | Disabled      | Disabled   | Unlimited |
| <input type="checkbox"/> | 3    | GE3   | Disabled      | Disabled   | Unlimited |
| <input type="checkbox"/> | 4    | GE4   | Disabled      | Disabled   | Unlimited |
| <input type="checkbox"/> | 5    | GE5   | Enabled       | Disabled   | Unlimited |
| <input type="checkbox"/> | 6    | GE6   | Disabled      | Disabled   | Unlimited |

- Configure on the port GE1-3 so that user defined remote ID can be set by Option 82. Click the “DHCP Snooping Configuration > Option 82 Function Configuration”, check and configure the port. “Apply” and finish as follows:

#### Port Setting Table

| Entry                    | Port  | State    | Allow Untrust |
|--------------------------|-------|----------|---------------|
| <input type="checkbox"/> | 1 GE1 | Disabled | Drop          |
| <input type="checkbox"/> | 2 GE2 | Disabled | Drop          |
| <input type="checkbox"/> | 3 GE3 | Enabled  | Replace       |
| <input type="checkbox"/> | 4 GE4 | Disabled | Drop          |
| <input type="checkbox"/> | 5 GE5 | Disabled | Drop          |

- Configure on the port GE1-3 so that the circuit ID can be set by Option 82. Click the “DHCP Snooping Configuration > Option 82 Circuit ID Function Configuration” to configure the port. “Apply” and finish as follows:

#### Option82 Circuit ID Table

Showing All entries      Showing 1 to 1 of 1 entries

| Port                         | VLAN | Circuit ID |
|------------------------------|------|------------|
| <input type="checkbox"/> GE3 | 1    | ge1/3      |

## 7 Network Security

### 7.1 DoS Attack Resistance

#### 7.1.1 Function Configuration

Enable the Attack Resistance option to make the switch more secure.

Instructions

- Click the “Security > DoS Attack Resistance > Function Configuration” to the “DoS

Global Configuration” to enable the “PoD Attack Resistance”, “Land Attack Resistance”, “Source/Destination MAC Same Packet Discarding”, “ICMP Fragment Packet Discarding”. “Apply” and finish as follows.

|                           |  |
|---------------------------|--|
| <b>POD</b>                | <input checked="" type="checkbox"/> Enable                             |
| <b>Land</b>               | <input checked="" type="checkbox"/> Enable                             |
| <b>UDP Blat</b>           | <input checked="" type="checkbox"/> Enable                             |
| <b>TCP Blat</b>           | <input checked="" type="checkbox"/> Enable                             |
| <b>DMAC = SMAC</b>        | <input checked="" type="checkbox"/> Enable                             |
| <b>Null Scan Attack</b>   | <input checked="" type="checkbox"/> Enable                             |
| <b>X-Mas Scan Attack</b>  | <input checked="" type="checkbox"/> Enable                             |
| <b>TCP SYN-FIN Attack</b> | <input checked="" type="checkbox"/> Enable                             |
| <b>TCP SYN-RST Attack</b> | <input checked="" type="checkbox"/> Enable                             |
| <b>ICMP Fragment</b>      | <input checked="" type="checkbox"/> Enable                             |
| <b>TCP-SYN</b>            | <input checked="" type="checkbox"/> Enable<br>Note: Source Port < 1024 |
| <b>TCP Fragment</b>       | <input checked="" type="checkbox"/> Enable<br>Note: Offset = 1         |
| <b>Ping Max Size</b>      | <input checked="" type="checkbox"/> Enable IPv4                        |
|                           | <input checked="" type="checkbox"/> Enable IPv6                        |
|                           | <input type="text" value="512"/> Byte (0 - 65535, default 512)         |
| <b>TCP Min Hdr size</b>   | <input checked="" type="checkbox"/> Enable                             |
|                           | <input type="text" value="20"/> Byte (0 - 31, default 20)              |
| <b>IPv6 Min Fragment</b>  | <input checked="" type="checkbox"/> Enable                             |
|                           | <input type="text" value="1240"/> Byte (0 - 65535, default 1240)       |
| <b>Smurf Attack</b>       | <input checked="" type="checkbox"/> Enable                             |
|                           | <input type="text" value="0"/> Netmask Length (0 - 32, default 0)      |

## 7.1.2 Port Configuration

DoS attack resistance is enabled based on ports.

Instructions

1. Click the “Security > DoS Attack Resistance > Port Configuration” as follows:

**Port Setting Table**

| <input type="checkbox"/> | Entry | Port | State    |
|--------------------------|-------|------|----------|
| <input type="checkbox"/> | 1     | GE1  | Disabled |
| <input type="checkbox"/> | 2     | GE2  | Disabled |
| <input type="checkbox"/> | 3     | GE3  | Disabled |
| <input type="checkbox"/> | 4     | GE4  | Disabled |

2. Select and “Modify” the port to enable or disable the DoS attack resistance function as follows.

**Edit Port Setting**

|              |  |
|--------------|--|
| <b>Port</b>  | GE1  |
| <b>State</b> | <input checked="" type="checkbox"/> Enable |

## 7.2 ACL Configuration

Expanding network scale and mounting flow strengthen the position of network security control and bandwidth allocation. Packet filtering prevents illegal users from accessing, control flow and saves network resources. ACL (Access Control List) filters packets by configuring the message matching rules and processing methods.

The switch port receiving messages analyzes the field according to the current ACL rules. Once a particular message is identified, it will be allowed or forbidden to flow through according to predetermined policies.

The packet matching rules defined by ACL can also be referenced by other functions requiring flow distinction such as the definition of QoS flow classification rules.

ACL can filter packets by setting matching rules and processing methods. ACL is a collection of permission and denial conditions applicable to packets. When the interface receives the packets, the switch compares the fields and ACL to determine the permitted and denied packets subject to specified standards. ACL classifies packets by matching conditions, which can be the source/destination MAC address, source/destination IP address, port No. and so on. ACL classifies packets by matching conditions, which can be the source/destination address, port No., etc. ACL can be divided into the following categories according to application purposes:

Basic IP ACL formulates rules based only on the source IP address of packets. ACL ID ranges from 100 to 999. Advanced IP ACL prepares rules according to packets’ source/destination IP address, protocol types carried by IP, and Layer 3 or 4 info such as protocol characteristics. ACL ID ranges from 100 to 999.

L2 ACL: Rules are made according to the packets’ source/destination MAC address, 802.1p priority, and L2 info such as protocol type. ACL ID ranges from 1 to 99.

## 7.2.1 MAC ACL Configuration

L2 ACL: Rules are made according to source/destination MAC address, VLAN priority, and L2 info such as protocol type.

Instructions:

1. Click on the “ACL > MAC ACL Configuration” in the navigation tree as follows.

Interface data are as follows.

| Configuration Items | Description            |
|---------------------|------------------------|
| ACL Name            | Name the MAC ACL Rules |

2. Click on the “ACL > MAC ACL Configuration” in the navigation tree, “Add” the ACL name as follows:

### ACE Table

Interface data are as follows.

| Configuration Items | Description   |
|---------------------|---|
| ACL Name            | ACL rule list is prepared based on MAC ACL configuration. |

3. Fill in corresponding configuration items.

### Add ACE

|                        |  |                  |
|------------------------|--|------------------|
| <b>ACL Name</b>        | a  |                  |
| <b>Sequence</b>        | 1  | (1 - 2147483647) |
| <b>Action</b>          | <input checked="" type="radio"/> Permit<br><input type="radio"/> Deny<br><input type="radio"/> Shutdown  |                  |
| <b>Source MAC</b>      | <input type="checkbox"/> Any<br><input type="text" value="00:00:00:00:20:00"/> / <input type="text" value="FF:FF:FF:FF:FF:00"/> (Address / Mask)   |                  |
| <b>Destination MAC</b> | <input type="checkbox"/> Any<br><input type="text" value="00:00:00:00:10:00"/> / <input type="text" value="FF:FF:FF:FF:FF:00"/> × (Address / Mask) |                  |
| <b>Ethertype</b>       | <input checked="" type="checkbox"/> Any<br><input type="text" value="0x"/> (0x600 ~ 0xFFFF)  |                  |
| <b>VLAN</b>            | <input checked="" type="checkbox"/> Any<br><input type="text"/> (1 - 4094)   |                  |
| <b>802.1p</b>          | <input checked="" type="checkbox"/> Any<br><input type="text"/> / <input type="text"/> (Value / Mask) (0 - 7)                                      |                  |

Interface data are as follows.

| Configuration Items     | Description   |
|-------------------------|---|
| Serial No.              | MAC ACL ranges from 1 to 2,147,483,647  |
| Action                  | ACL actions are divided into “Permit” or “Deny”, as well as “Shutdown”.   |
| Source MAC Address      | Enter the source MAC address and mask of ACL rules with the format of H.H.H.H.H.H. Select “Any” to represent any MAC address      |
| Destination MAC Address | Enter the destination MAC address and mask of ACL rules with the format of H.H.H.H.H.H. Select “Any” to represent any MAC address |
| Ethernet Type           | Enter the Ethernet type of ACL rules ranging from 0 x 600 to 0 x ffff, select “Any” to represent any type.                        |
| VLAN                    | Enter the VLAN of ACL rules ranging from 1 to 4,094, select “Any” to represent any VLAN   |
| 802.1p                  | Enter the VLAN priority and mask of ACL rules ranging from 1 to 7, select “Any” to represent any VLAN priority                    |

4. “Apply” and finish as follows.

#### ACE Table

ACL Name

Showing  entries      Showing 1 to 1 of 1 entries

| Sequence                 | Action | Source MAC |                   | Destination MAC   |                   | Ethertype         | VLAN | 802.1p |      |
|--------------------------|--------|------------|-------------------|-------------------|-------------------|-------------------|------|--------|------|
|                          |        | Address    | Mask              | Address           | Mask              |                   |      | Value  | Mask |
| <input type="checkbox"/> | 1      | Permit     | 00:00:00:00:20:00 | FF:FF:FF:FF:FF:00 | 00:00:00:00:10:00 | FF:FF:FF:FF:FF:00 | Any  | Any    | Any  |

## 7.2.2 IPv4 ACL Configuration

IPv4-based ACL (Basic IP ACL) formulates rules as per the source IP address of packets only. ACL ID ranges from 100 to 999.

Advanced IP ACL Rules are made according to the packets' source/destination IP address, protocol type carried by IP, and Layer 3 or 4 info such as protocol characteristics. ACL ID ranges from 100 to 999.

Instructions

1. Click on the “ACL > IPv4 ACL Configuration” in the navigation tree as follows.

Interface data are as follows.

| Configuration Items | Description             |
|---------------------|-------------------------|
| ACL Name            | Name the IPv4 ACL rules |

2. Click on the “ACL > IPv4 ACE Configuration” in the navigation tree, “Add” the ACL Name as follows:

Interface data are as follows.

| Configuration Items | Description  |
|---------------------|--|
| ACL Name            | ACL rule list is made based on IPv4 ACL configuration. |

3. Fill in corresponding configuration items.

### Add ACE

|                         |  |
|-------------------------|--|
| <b>ACL Name</b>         | B  |
| <b>Sequence</b>         | 100 (1 - 2147483647)   |
| <b>Action</b>           | <input checked="" type="radio"/> Permit<br><input type="radio"/> Deny<br><input type="radio"/> Shutdown  |
| <b>Protocol</b>         | <input checked="" type="radio"/> Any<br><input type="radio"/> Select ICMP<br><input type="radio"/> Define (0 - 255)  |
| <b>Source IP</b>        | <input checked="" type="checkbox"/> Any<br><input type="text"/> / <input type="text"/> (Address / Mask)  |
| <b>Destination IP</b>   | <input checked="" type="checkbox"/> Any<br><input type="text"/> / <input type="text"/> (Address / Mask)  |
| <b>Type of Service</b>  | <input checked="" type="radio"/> Any<br><input type="radio"/> DSCP (0 - 63)<br><input type="radio"/> IP Precedence (0 - 7)   |
| <b>Source Port</b>      | <input checked="" type="radio"/> Any<br><input type="radio"/> Single (0 - 65535)<br><input type="radio"/> Range - (0 - 65535)  |
| <b>Destination Port</b> | <input checked="" type="radio"/> Any<br><input type="radio"/> Single (0 - 65535)<br><input type="radio"/> Range - (0 - 65535)  |
| <b>TCP Flags</b>        | Urg: <input type="radio"/> Set <input type="radio"/> Unset <input checked="" type="radio"/> Don't care<br>Ack: <input type="radio"/> Set <input type="radio"/> Unset <input checked="" type="radio"/> Don't care<br>Psh: <input type="radio"/> Set <input type="radio"/> Unset <input checked="" type="radio"/> Don't care<br>Rst: <input type="radio"/> Set <input type="radio"/> Unset <input checked="" type="radio"/> Don't care<br>Syn: <input type="radio"/> Set <input type="radio"/> Unset <input checked="" type="radio"/> Don't care<br>Fin: <input type="radio"/> Set <input type="radio"/> Unset <input checked="" type="radio"/> Don't care |
| <b>ICMP Type</b>        | <input checked="" type="radio"/> Any<br><input type="radio"/> Select Echo Reply<br><input type="radio"/> Define (0 - 255)  |
| <b>ICMP Code</b>        | <input checked="" type="radio"/> Any<br><input type="radio"/> Define (0 - 255)   |

Interface data are as follows.

| Configuration Items | Description   |
|---------------------|---|
| No.                 | IPv4 ACL ranges from 1 to 2,147,483,647.  |
| Action              | ACL actions are divided into “Permit” or “Deny”, as well as “Shutdown”.                                       |
| Protocol            | It is required to select the protocol type such as ICMP, TCP and UDP. Select “Any” to represent any protocol. |
| Source IP           | Enter the source IP and mask of ACL rules. Select “Any” to  |

|                  |   |
|------------------|---|
|                  | represent any source IP.  |
| Destination IP   | Enter the destination IP and mask of ACL rules. Select “Any” to represent any destination IP.   |
| Service Type     | Enter the service type of ACL rules, such as DSCP (0-63) and IP priority (0-7). Select “Any” to represent any service type.                   |
| Source Port      | Enter the source port of ACL rules, such as single port No. or range segment (0-65,535). Select “Any” to represent any source port.           |
| Destination Port | Enter the destination port of ACL rules, such as single port No. or range segment (0-65,535). Select “Any” to represent any destination port. |
| TCP Flags        | Enter the TCP flags of ACL rules, such as URG, ACK, PSH, RST, SYN, FIN, with the actions such as “Set”, “Unset” and “Don’t care”.             |
| ICMP Type        | Enter the ICMP message type of ACL rules. Select “Any” to represent any ICMP type.  |
| ICMP Field       | Enter the ICMP field value of ACL rules. Select “Any” to represent any field value.   |

3. “Apply” and finish as follows.

**ACE Table**

ACL Name

Showing  entries Showing 1 to 1 of 1 entries

|                          | Sequence | Action | Protocol | Source IP |      | Destination IP |      | Source Port | Destination Port | TCP Flags | Type of Service |               | ICMP |      |
|--------------------------|----------|--------|----------|-----------|------|----------------|------|-------------|------------------|-----------|-----------------|---------------|------|------|
|                          |          |        |          | Address   | Mask | Address        | Mask |             |                  |           | DSCP            | IP Precedence | Type | Code |
| <input type="checkbox"/> | 100      | Permit | Any (IP) | Any       | Any  | Any            | Any  |             |                  |           | Any             |               | Any  |      |

## 7.2.3 IPv6 ACL Configuration

Instructions

1. Click the “ACL > IPv6 ACL Configuration” in the navigation tree as follows.

**ACL Name**

Interface data are as follows.

| Configuration Items | Description             |
|---------------------|-------------------------|
| ACL Name            | Name the IPv6 ACL rules |

2. Click the “ACL > IPv6 ACE Configuration” in the navigation tree, “Add” the ACL Name as follows:

### ACE Table

ACL Name

Showing  entries      Showing 0 to 0 of 0 entries     

|                  | Sequence | Action | Protocol | Source IP |        | Destination IP |        | Source Port | Destination Port | TCP Flags | Type of Service |               | ICMP |      |
|------------------|----------|--------|----------|-----------|--------|----------------|--------|-------------|------------------|-----------|-----------------|---------------|------|------|
|                  |          |        |          | Address   | Prefix | Address        | Prefix |             |                  |           | DSCP            | IP Precedence | Type | Code |
| 0 results found. |          |        |          |           |        |                |        |             |                  |           |                 |               |      |      |

Interface data are as follows.

| Configuration Items | Description  |
|---------------------|--|
| ACL Name            | ACL rule list is made based on IPv6 ACL configuration. |

3. Fill in corresponding configuration items

### Add ACE

|                  |  |
|------------------|--|
| ACL Name         | b  |
| Sequence         | 100 (1 - 2147483647)   |
| Action           | <input checked="" type="radio"/> Permit<br><input type="radio"/> Deny<br><input type="radio"/> Shutdown  |
| Protocol         | <input checked="" type="radio"/> Any<br><input type="radio"/> Select <span>TCP</span><br><input type="radio"/> Define <span>(0 - 255)</span>   |
| Source IP        | <input checked="" type="checkbox"/> Any<br><input type="checkbox"/> <span>/</span> <span>(Address / Prefix (0 - 128))</span>   |
| Destination IP   | <input checked="" type="checkbox"/> Any<br><input type="checkbox"/> <span>/</span> <span>(Address / Prefix (0 - 128))</span>   |
| Type of Service  | <input checked="" type="radio"/> Any<br><input type="radio"/> DSCP <span>(0 - 63)</span><br><input type="radio"/> IP Precedence <span>(0 - 7)</span>   |
| Source Port      | <input checked="" type="radio"/> Any<br><input type="radio"/> Single <span>(0 - 65535)</span><br><input type="radio"/> Range <span>(0 - 65535)</span>  |
| Destination Port | <input checked="" type="radio"/> Any<br><input type="radio"/> Single <span>(0 - 65535)</span><br><input type="radio"/> Range <span>(0 - 65535)</span>  |
| TCP Flags        | Urg: <input type="radio"/> Set <input type="radio"/> Unset <input checked="" type="radio"/> Don't care<br>Ack: <input type="radio"/> Set <input type="radio"/> Unset <input checked="" type="radio"/> Don't care<br>Psh: <input type="radio"/> Set <input type="radio"/> Unset <input checked="" type="radio"/> Don't care<br>Rst: <input type="radio"/> Set <input type="radio"/> Unset <input checked="" type="radio"/> Don't care<br>Syn: <input type="radio"/> Set <input type="radio"/> Unset <input checked="" type="radio"/> Don't care<br>Fin: <input type="radio"/> Set <input type="radio"/> Unset <input checked="" type="radio"/> Don't care |
| ICMP Type        | <input checked="" type="radio"/> Any<br><input type="radio"/> Select <span>Destination Unreachable</span><br><input type="radio"/> Define <span>(0 - 255)</span>   |
| ICMP Code        | <input checked="" type="radio"/> Any<br><input type="radio"/> Define <span>(0 - 255)</span>  |

Interface data are as follows.

| Configuration Items | Description   |
|---------------------|---|
| No.                 | IPv6 ACL ranges from 1 to 2,147,483,647.  |
| Action              | ACL actions are divided into “Permit” or “Deny”, as well as “Shutdown”.                                       |
| No.                 | MAC ACL ranges from 1 to 2,147,483,647.   |
| Protocol            | It is required to select the protocol type such as ICMP, TCP and UDP. Select “Any” to represent any protocol. |

|                  |   |
|------------------|---|
| Source IP        | Enter the source IP and mask of ACL rules. Select “Any” to represent any source IP.   |
| Destination IP   | Enter the destination IP and mask of ACL rules. Select “Any” to represent any destination IP.   |
| Service Type     | Enter the service type of ACL rules, such as DSCP (0-63) and IP priority (0-7). Select “Any” to represent any service type.                   |
| Source Port      | Enter the source port of ACL rules, such as single port No. or range segment (0-65,535). Select “Any” to represent any source port.           |
| Destination Port | Enter the destination port of ACL rules, such as single port No. or range segment (0-65,535). Select “Any” to represent any destination port. |
| TCP Flags        | Enter the TCP flags of ACL rules, such as URG, ACK, PSH, RST, SYN, FIN, with the actions such as “Set”, “Unset” and “Don’t care”.             |
| ICMP Type        | Enter the ICMP message type of ACL rules. Select “Any” to represent any ICMP type.  |
| ICMP Field       | Enter the ICMP field value of ACL rules. Select “Any” to represent any field value.   |

3. “Apply” and finish as follows.

#### ACE Table

ACL Name

Showing  entries Showing 1 to 1 of 1 entries

| Sequence                 | Action | Protocol | Source IP |        | Destination IP |        | Source Port | Destination Port | TCP Flags | Type of Service |               | ICMP |      |
|--------------------------|--------|----------|-----------|--------|----------------|--------|-------------|------------------|-----------|-----------------|---------------|------|------|
|                          |        |          | Address   | Prefix | Address        | Prefix |             |                  |           | DSCP            | IP Precedence | Type | Code |
| <input type="checkbox"/> | 100    | Permit   | Any (IP)  | Any    | Any            | Any    |             |                  |           | Any             |               | Any  |      |

## 7.2.4 ACL Binding Configuration

Once the list is created, it must be bound to each required interface.

Instructions:

1. Click the “ACL > ACL Binding” in the navigation tree as follows.

#### ACL Binding Table

Q

| Entry                    | Port | MAC ACL | IPv4 ACL | IPv6 ACL |
|--------------------------|------|---------|----------|----------|
| <input type="checkbox"/> | 1    | GE1     |          |          |
| <input type="checkbox"/> | 2    | GE2     |          |          |
| <input type="checkbox"/> | 3    | GE3     |          |          |
| <input type="checkbox"/> | 4    | GE4     |          |          |

Interface data are as follows.

| Configuration Items | Description  |
|---------------------|--|
| MAC ACL             | MAC ACL name bound to the port                                     |
| IPv4 ACL            | IPv4 ACL name bound to the port (mutually exclusive with IPv6 ACL) |
| IPv6 ACL            | IPv6 ACL name bound to the port (mutually exclusive with IPv4 ACL) |

- Fill in corresponding configuration items, taking the created MAC ACL a, IPv4 ACL b, IPv6 ACL c as examples.
- “Apply” and finish as follows.

#### Add ACL Binding

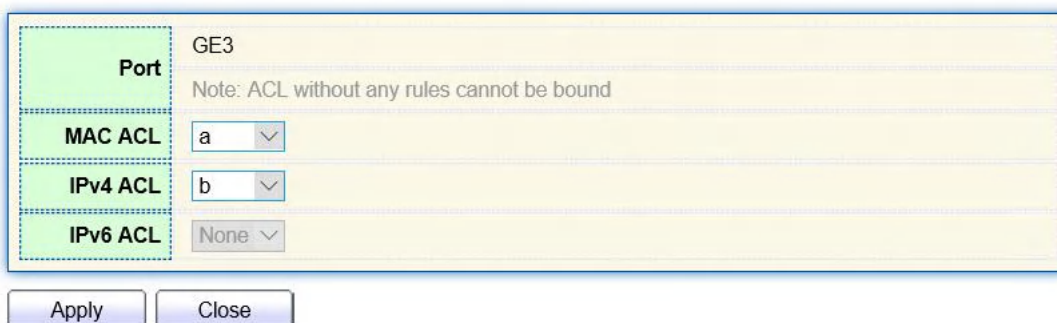

Port: GE3  
 Note: ACL without any rules cannot be bound  
 MAC ACL: a  
 IPv4 ACL: b  
 IPv6 ACL: None

Apply Close

## 8 Advanced Configuration

QoS (Quality of Service) assesses the ability of service providers to meet customer needs and the ability of transmitting packets over the Internet. Diversified services can be assessed based on different aspects. QoS usually refers to the evaluation of service capabilities that support core requirements such as bandwidth, delay, delay variation, and packet loss rate during delivery. Bandwidth, also known as throughput, refers to the average rate of business flow in a given period of time, with the unit of Kbit/s. Delay refers to the average time required for business flowing through the network. For a network device, the followings are general levels of delay requirements. There are two delay levels, that is, the high-priority business can be served as soon as possible by scheduling method of priority queue, while the low-priority business gets services after that. Delay variation refers to the time change of business flowing through the network. Packet loss rate refers to the percentage of lost business flow during transmission. As modern transmission systems are very reliable, information is often lost in network congestion. Packet loss due to queue overflow is the most common situation.

All messages in a traditional IP network are treated equally. Every network device processes the messages on a FIFO basis, and makes every effort to transmit them to destinations without guaranteeing reliability, transfer delay, or other performance.

Network service quality is constantly improved as new applications keep springing up in the

rapidly changing IP network. For example, VoIP, video and other delay-sensitive services have set higher standards on message transmission delay. Message transmission in a short period has been the common trend. In order to support voice, video and data services with different requirements, the network needs to identify business types and provide corresponding services.

The ability to distinguish business types is the prerequisite to provide corresponding services, so the traditional best-effort service no longer meets the application needs. Therefore, QoS comes into being. It regulates the network flow to avoid and handle network congestion and reduce packet loss rate. Meanwhile, users can enjoy dedicated bandwidths while business can improve service quality, thus perfecting the network service capacity.

QoS priorities vary with message types. For instance, the VLAN message uses 802.1p, also known as the CoS (Class of Service) field, while the IP message uses DSCP. To maintain the priority, these fields need to be mapped at the gateway connected with various networks when messages flow through the network.

#### 802.1p priority in the VLAN frame header

Typically, VLAN frames are interacted between Layer 2 devices. The PRI field (i.e. 802.1p priority), or CoS field, in the VLAN frame header identifies the quality of service requirements according to the definitions in IEEE 802.1Q.

#### 802.1p priority in the VLAN frame

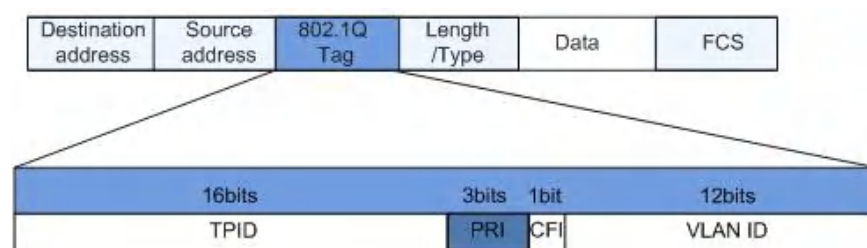

The 802.1Q header contains 3-bit PRI fields. PRI field defines 8 CoS of business priority ranging from 7 to 0 from high to low.

#### IP Precedence/DSCP Field

According to RFC791 definition, ToS (Type of Service) domain in the IP message header is composed of 8 bits. Among them, the 3-bit long Precedence field, as located in the following, identifies the IP message priority.

#### IP Precedence/DSCP Field

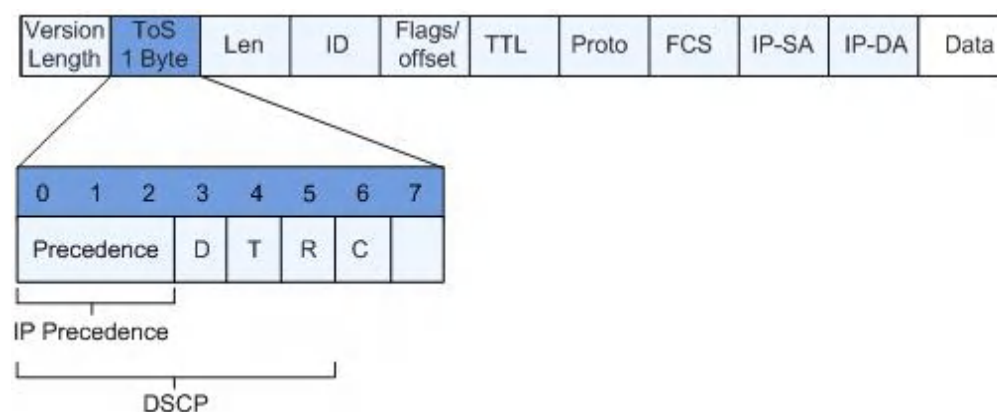

0 to 2 bits are Precedence fields representing the 8 priorities of message transmission ranging

from 7 to 0 from high to low, with either Level 7 or 6 as the highest priority that is generally reserved for routing or updating network control communication. User-level applications only have access to Level 0 to 5.

ToS domain, in addition to Precedence fields, also includes D, T and R bits: D-bit represents the Delay requirement (0 for normal delay and 1 for low delay). T-bit represents the throughput (0 for normal throughput and 1 for high throughput). R-bit represents the reliability (0 for normal reliability and 1 for high reliability). ToS domain reserves the 6 and 7 bits.

RFC1349 redefines the ToS domain by adding a C-bit to represent the Monetary Cost. The IETF DiffServ group then redefines the 0 to 5 bits of ToS domain in the IPv4 message header of RFC2474 as DSCP and renames it as DS (Differentiated Service) byte as shown in the figure above.

The first 6 bits (0-5 bits) of DS field distinguish the DSCP (DS Code Point), and the higher 2 bits (6-7 bits) are reserved. The lower 3 bits (0-2 bits) are CSCP (Class Selector Code Point), with the same CSCP value representing the DSCP of the same class. DS nodes select corresponding PHB (Per-Hop Behavior) according to DSCP values.

## 8.1 QoS Configuration

### 8.1.1 Basic Configuration

Network congestion resulting from the competition for resource use rights among messages at the same time is usually solved by queue scheduling, thus avoiding intermittent congestions. Queue scheduling technologies include SP (Strict-Priority), WFQ (Weighted Fair Queue), WRR (Weighted Round Robin), and DRR (Deficit Round Robin, which is also expanded from RR technology).

Instructions for global and port scheduling configuration

1. Click the “QoS > Basic Function > Function Configuration” in the navigation tree as follows.

|                   |   |
|-------------------|---|
| <b>State</b>      | <input type="checkbox"/> Enable   |
| <b>Trust Mode</b> | <input checked="" type="radio"/> CoS<br><input type="radio"/> DSCP<br><input type="radio"/> CoS-DSCP<br><input type="radio"/> IP Precedence |

### Port Setting Table

| □                        | Entry | Port | CoS | Trust   | Remarking |          |               |
|--------------------------|-------|------|-----|---------|-----------|----------|---------------|
|                          |       |      |     |         | CoS       | DSCP     | IP Precedence |
| <input type="checkbox"/> | 1     | GE1  | 0   | Enabled | Disabled  | Disabled | Disabled      |
| <input type="checkbox"/> | 2     | GE2  | 0   | Enabled | Disabled  | Disabled | Disabled      |
| <input type="checkbox"/> | 3     | GE3  | 0   | Enabled | Disabled  | Disabled | Disabled      |

Interface data of global configuration are as follows.

| Configuration Items | Description  |
|---------------------|--|
| State               | Switch of global QoS function                              |
| Trust Mode          | It can be divided into CoS, DSCP, CoS-DSCP and IP priority |

Interface data of port configuration are as follows.

| Configuration Items | Description                 |
|---------------------|-----------------------------|
| CoS                 | Ranging from 0 to 7         |
| Port Trust Mode     | Switch of port QoS function |
| CoS                 | Mark the CoS field          |
| DSCP                | Mark the DSCP field         |
| IP Priority         | Mark the IP Priority field  |

## 8.1.2 Queue Scheduling

1. Click the “QoS > Queue Scheduling”. “Apply” and finish as follows.

**Queue Scheduling Table**

| Queue | Method                           |                       |        |                   |
|-------|----------------------------------|-----------------------|--------|-------------------|
|       | Strict Priority                  | WRR                   | Weight | WRR Bandwidth (%) |
| 1     | <input checked="" type="radio"/> | <input type="radio"/> | 1      |                   |
| 2     | <input checked="" type="radio"/> | <input type="radio"/> | 2      |                   |
| 3     | <input checked="" type="radio"/> | <input type="radio"/> | 3      |                   |
| 4     | <input checked="" type="radio"/> | <input type="radio"/> | 4      |                   |
| 5     | <input checked="" type="radio"/> | <input type="radio"/> | 5      |                   |
| 6     | <input checked="" type="radio"/> | <input type="radio"/> | 9      |                   |
| 7     | <input checked="" type="radio"/> | <input type="radio"/> | 13     |                   |
| 8     | <input checked="" type="radio"/> | <input type="radio"/> | 15     |                   |

Interface data are as follows.

| Configuration Items | Description  |
|---------------------|--|
| SP                  | SP mode  |
| WRR                 | WRR mode   |
| Weight              | Bandwidth percentage of WRR accounted for by Queue |

### 8.1.3 CoS Mapping

1. Click the “QoS > CoS Mapping” in the navigation tree. “Apply” and finish as follows.

### CoS to Queue Mapping

| CoS | Queue |
|-----|-------|
| 0   | 2     |
| 1   | 1     |
| 2   | 3     |
| 3   | 4     |
| 4   | 5     |
| 5   | 6     |
| 6   | 7     |
| 7   | 8     |

Apply

### Queue to CoS Mapping

| Queue | CoS |
|-------|-----|
| 1     | 1   |
| 2     | 0   |
| 3     | 2   |
| 4     | 3   |
| 5     | 4   |
| 6     | 5   |
| 7     | 6   |
| 8     | 7   |

Apply

Interface data are as follows.

| Configuration Items | Description  |
|---------------------|--|
| SP                  | SP mode  |
| WRR                 | WRR mode   |
| Weight              | Bandwidth percentage of WRR accounted for by Queue |

## 8.1.4 DSCP Mapping

1. Click the “QoS > Queue Scheduling”. “Apply” and finish as follows.

### DSCP to Queue Mapping

| DSCP      | Queue | DSCP      | Queue | DSCP      | Queue | DSCP     | Queue |
|-----------|-------|-----------|-------|-----------|-------|----------|-------|
| 0 [CS0]   | 1     | 16 [CS2]  | 3     | 32 [CS4]  | 5     | 48 [CS6] | 7     |
| 1         | 1     | 17        | 3     | 33        | 5     | 49       | 7     |
| 2         | 1     | 18 [AF21] | 3     | 34 [AF41] | 5     | 50       | 7     |
| 3         | 1     | 19        | 3     | 35        | 5     | 51       | 7     |
| 4         | 1     | 20 [AF22] | 3     | 36 [AF42] | 5     | 52       | 7     |
| 5         | 1     | 21        | 3     | 37        | 5     | 53       | 7     |
| 6         | 1     | 22 [AF23] | 3     | 38 [AF43] | 5     | 54       | 7     |
| 7         | 1     | 23        | 3     | 39        | 5     | 55       | 7     |
| 8 [CS1]   | 2     | 24 [CS3]  | 4     | 40 [CS5]  | 6     | 56 [CS7] | 8     |
| 9         | 2     | 25        | 4     | 41        | 6     | 57       | 8     |
| 10 [AF11] | 2     | 26 [AF31] | 4     | 42        | 6     | 58       | 8     |
| 11        | 2     | 27        | 4     | 43        | 6     | 59       | 8     |
| 12 [AF12] | 2     | 28 [AF32] | 4     | 44        | 6     | 60       | 8     |
| 13        | 2     | 29        | 4     | 45        | 6     | 61       | 8     |
| 14 [AF13] | 2     | 30 [AF33] | 4     | 46 [EF]   | 6     | 62       | 8     |
| 15        | 2     | 31        | 4     | 47        | 6     | 63       | 8     |

Apply

### Queue to DSCP Mapping

| Queue | DSCP     |
|-------|----------|
| 1     | 0 [CS0]  |
| 2     | 8 [CS1]  |
| 3     | 16 [CS2] |
| 4     | 24 [CS3] |
| 5     | 32 [CS4] |
| 6     | 40 [CS5] |
| 7     | 48 [CS6] |
| 8     | 56 [CS7] |

Apply

Interface data are as follows.

| Configuration Items | Description  |
|---------------------|--|
| SP                  | SP mode  |
| WRR                 | WRR mode   |
| Weight              | Bandwidth percentage of WRR accounted for by Queue |

## 8.1.5 IP Priority Mapping

1. Click the “QoS > Basic Functions > IP Precedence Mapping”, enter this page and click “Apply”, finish as follows.

### IP Precedence to Queue Mapping

| IP Precedence | Queue |
|---------------|-------|
| 0             | 1     |
| 1             | 2     |
| 2             | 3     |
| 3             | 4     |
| 4             | 5     |
| 5             | 6     |
| 6             | 7     |
| 7             | 8     |

Apply

### Queue to IP Precedence Mapping

| Queue | IP Precedence |
|-------|---------------|
| 1     | 0             |
| 2     | 1             |
| 3     | 2             |
| 4     | 3             |
| 5     | 4             |
| 6     | 5             |
| 7     | 6             |
| 8     | 7             |

Apply

Interface data are as follows.

| Configuration Items | Description  |
|---------------------|--|
| SP                  | SP mode  |
| WRR                 | WRR mode   |
| Weight              | Bandwidth percentage of WRR accounted for by Queue |

## 8.2 LLDP Configuration

LLDP (Link Layer Discovery Protocol) is defined in IEEE 802.1ab. It is a standard L2 discovery method which integrates the info such as management addresses, device and interface identifications of local network devices and transmits to the neighbor devices. After receiving the info, they will save it in form of standard MIB (Management Information Base) for NMS query and link communication judgment.

It can also integrate the info and transmit to its own remote devices. The info received by the local network device will be kept in the form of MIB. The following shows how it works.

Block diagram of LLDP principles

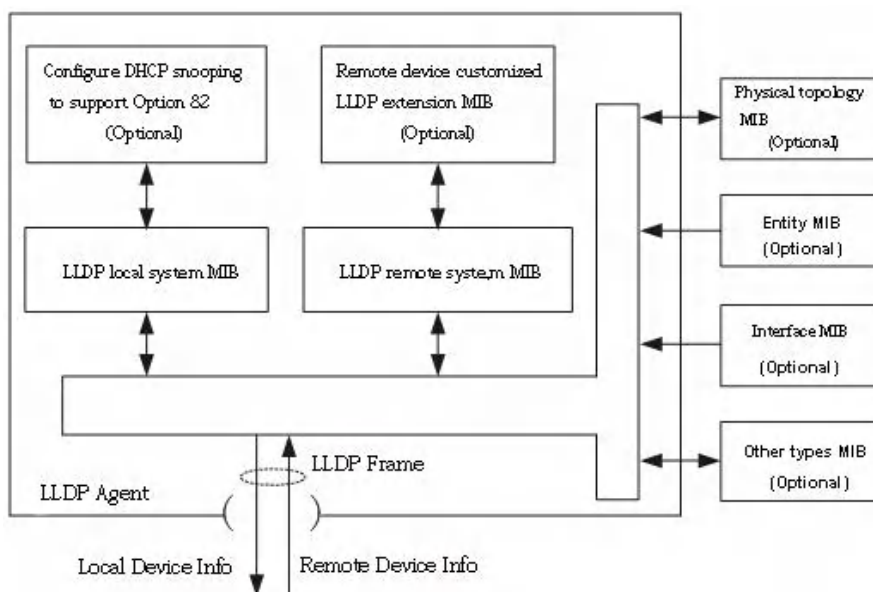

LLDP is realized based on:

- LLDP module updates its local system MIB, as well as the customized extension MIB, through the interaction between LLDP agent and MIBs of physical topology, entity, interface and other types.
- Encapsulate the info of local network device into LLDP frames and transmit to the remote device.
- Receive the LLDP frame sent by the remote device to update LLDP remote system MIB and customized extension MIB.
- Master the info of remote device such as connection interface and MAC address through the transmitting & receiving function of LLDP agent.
- The local system MIB stores local device info, including device and interface IDs, system name and description, interface description, network management address, etc.
- The remote system MIB stores local device info, including device and interface IDs, system name and description, interface description, network management address, etc.

Based on LLDP, LLDP-MED allows other units to expand. The info checked by network devices facilitates fault analysis and deepens the accurate understanding of network topology by management system.

## 8.2.1 LLDP Function Configuration

Instructions:

1. Click the “Topology Discovery > LLDP > Function Configuration” in the navigation tree as follows.

| LLDP                    |  |
|-------------------------|--|
| State                   | <input checked="" type="checkbox"/> Enable   |
| LLDP Handling           | <input type="radio"/> Filtering<br><input type="radio"/> Bridging<br><input checked="" type="radio"/> Flooding |
| TLV Advertise Interval  | 30 Sec (5 - 32767, default 30)   |
| Hold Multiplier         | 4 (2 - 10, default 4)  |
| Reinitializing Delay    | 2 Sec (1 - 10, default 2)  |
| Transmit Delay          | 2 Sec (1 - 8191, default 2)  |
| LLDP-MED                |  |
| Fast Start Repeat Count | 3 (1 - 10, default 3)  |

Apply

Interface data are as follows.

| Configuration Items      | Description   |
|--------------------------|---|
| State                    | Enable or disable the LLDP  |
| LLDP Message Processing  | LLDP messages will be processed by means of “Filtering”, “Bridging” and “Flooding” when disabling the LLDP.                     |
| Transmission Period      | 30s by default ranging from 5 to 32,768s.   |
| Hold Multiplier          | Transmission period product with 4 by default ranges from 2 to 10. Transmission period * product should be no more than 65,535. |
| Delay Re-initialization  | 2s by default ranging from:1 to 10s.  |
| Transfer Delay           | 2s by default ranging from:1 to 8,191s.   |
| Repeat Count Quick Start | 3s by default of the LLDP-MED port ranging from 1 to 10s.   |

Ethernet message encapsulated with LLDPDU (LLDP Data Unit) are recognized as LLDP message. Each TLV is a unit of LLDPDU carried with specified info.

2. Fill in corresponding configuration items
3. “Apply” and finish.

## 8.2.2 Port Configuration

Instructions

1. Click the “Topology Discovery > LLDP > Port Configuration” in the navigation tree as follows.

## Port Setting Table

| <input type="checkbox"/> | Entry | Port | Mode   | Selected TLV |
|--------------------------|-------|------|--------|--------------|
| <input type="checkbox"/> | 1     | GE1  | Normal | 802.1 PVID   |
| <input type="checkbox"/> | 2     | GE2  | Normal | 802.1 PVID   |
| <input type="checkbox"/> | 3     | GE3  | Normal | 802.1 PVID   |
| <input type="checkbox"/> | 4     | GE4  | Normal | 802.1 PVID   |

Interface data are as follows.

| Configuration Items           | Description                        |
|-------------------------------|------------------------------------|
| Port                          | Multiple ports are available.      |
| Transmitting & Receiving Mode | LLDP transmitting & receiving mode |
| Selected TLV                  | Info of selected TLV and VLAN      |

LLDP can work in 4 patterns: Transmit: transmit LLDP messages only; Receive: receive LLDP messages only; Normal: transmit and receive LLDP messages; Disable: neither transmit nor receive LLDP messages.

2. Check corresponding port and “Modify” the port configuration. “Apply” and finish as follows.

### Edit Port Setting

|  |   |                |               |  |   |
|--|---|----------------|---------------|--|---|
| <b>Port</b>  | GE1   |                |               |  |   |
| <b>Mode</b>  | <input type="radio"/> Transmit<br><input type="radio"/> Receive<br><input checked="" type="radio"/> Normal<br><input type="radio"/> Disable   |                |               |  |   |
| <b>Optional TLV</b>  | <table style="width: 100%;"> <tr> <td style="width: 50%;">Available TLV</td> <td style="width: 50%;">Selected TLV</td> </tr> <tr> <td> <div style="border: 1px solid #ccc; padding: 2px;">           Port Description<br/>           System Name<br/>           System Description<br/>           System Capabilities<br/>           802.3 MAC-PHY         </div> </td> <td> <div style="border: 1px solid #ccc; padding: 2px;">           802.1 PVID         </div> </td> </tr> </table> | Available TLV  | Selected TLV  | <div style="border: 1px solid #ccc; padding: 2px;">           Port Description<br/>           System Name<br/>           System Description<br/>           System Capabilities<br/>           802.3 MAC-PHY         </div> | <div style="border: 1px solid #ccc; padding: 2px;">           802.1 PVID         </div> |
| Available TLV  | Selected TLV  |                |               |  |   |
| <div style="border: 1px solid #ccc; padding: 2px;">           Port Description<br/>           System Name<br/>           System Description<br/>           System Capabilities<br/>           802.3 MAC-PHY         </div> | <div style="border: 1px solid #ccc; padding: 2px;">           802.1 PVID         </div>   |                |               |  |   |
| <b>802.1 VLAN Name</b>   | <table style="width: 100%;"> <tr> <td style="width: 50%;">Available VLAN</td> <td style="width: 50%;">Selected VLAN</td> </tr> <tr> <td> <div style="border: 1px solid #ccc; padding: 2px;">           VLAN 1         </div> </td> <td> <div style="border: 1px solid #ccc; padding: 2px;">           [Empty]         </div> </td> </tr> </table>   | Available VLAN | Selected VLAN | <div style="border: 1px solid #ccc; padding: 2px;">           VLAN 1         </div>  | <div style="border: 1px solid #ccc; padding: 2px;">           [Empty]         </div>    |
| Available VLAN   | Selected VLAN   |                |               |  |   |
| <div style="border: 1px solid #ccc; padding: 2px;">           VLAN 1         </div>  | <div style="border: 1px solid #ccc; padding: 2px;">           [Empty]         </div>  |                |               |  |   |

Interface data are as follows.

| Configuration Items           | Description  |
|-------------------------------|--|
| Port                          | Multiple ports are available   |
| Transmitting & Receiving Mode | LLDP transmitting & receiving mode. Transmit: transmit LLDP messages only; Receive: receive LLDP messages only; Normal: transmit and receive LLDP messages; Disable: neither transmit nor receive LLDP messages. |
| Optional TLV                  | Select the info of TLV and VLAN  |
| VLAN Name                     | Select the VLAN name   |

### 8.2.3 Neighbor Info

Instructions for LLDP neighbor displaying

Click the “Topology Discovery > LLDP > Neighbor Info” in the navigation tree as follows.

**Neighbor Table**

Showing  entries      Showing 1 to 1 of 1 entries     

| <input type="checkbox"/> | Local Port | Chassis ID Subtype | Chassis ID        | Port ID Subtype | Port ID | System Name | Time to Live |
|--------------------------|------------|--------------------|-------------------|-----------------|---------|-------------|--------------|
| <input type="checkbox"/> | GE9        | MAC address        | 00:E0:41:00:00:02 | Local           | gi13    |             | 118          |

## 8.3 SNMP Configuration

SNMP (Simple Network Management Protocol) is widely used in TCP/IP network. It manages devices by the central computer which operates network management software (i.e. network management workstation). SNMP is:

Simple: The polling-driving SNMP has the fundamental functionality set that is applicable to small-scale environment with fast speed and low cost. Besides, UDP-driven SNMP is compatible with most devices. Powerful: SNMP aims to ensure the management info transmission between two nodes so that administrators can retrieve, modify and troubleshoot the info easily. There are 3 common versions, namely SNMPv1, v2c and v3. Its system contains NMS (Network Management System), Agent, Management object and MIB (Management Information Base).

NMS, as the management center, will manage all devices. Each device under management includes the resident Agent, MIB and management objects. NMS interacts with the Agent running on the management object which will operate the MIB to execute NMS orders.

SNMP management model

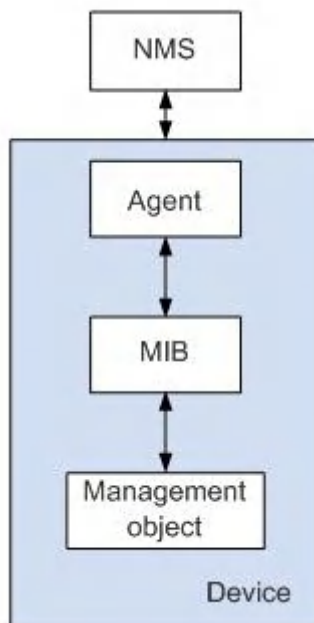

#### NMS

- As the network administrator, NMS manages/monitors network devices by SNMP on its server. It can request the Agent to inquire or modify specified parameter(s). NMS can receive the Trap actively sent by the Agent to be updated with the states of the managed devices.

#### Agent

- As an agent process of the managed devices, it maintains device data and responds to the NMS requests by reporting management data. Agent will fulfill relevant orders through MIB Table and transmit the results back to NMS after receiving its request. Devices will take the initiative to transmit info related to the current statuses of devices to NMS through Agent once a fault or another event occurs.

#### Management object

- It refers to the object under management. Each device may have more than one objects, including a piece of hardware (e.g. an interface board), partial hardware and software (e.g. routing protocol), as well as other configuration item sets

#### MIB

- MIB is a database specifying the variables maintained by the management object (i.e. the info that can be inquired and set by the Agent). MIB defines the attributes of the management object, including the name, state, access right and data type. The following functions can be realized through MIB: Agent will master the instant device info by inquiring MIB and set the state configuration items by changing MIB.

### 8.3.1 View Configuration

1. Click the “Device Management > SNMP Configuration > View Configuration” in the navigation tree as follows.

### View Table

Showing  entries      Showing 1 to 1 of 1 entries     

| <input type="checkbox"/> | View | OID Subtree | Type     |
|--------------------------|------|-------------|----------|
| <input type="checkbox"/> | all  | .1          | Included |

Interface data are as follows.

|                     |                                     |
|---------------------|-------------------------------------|
| Configuration Items | Description                         |
| View                | View name                           |
| OID                 | View OID                            |
| Type                | View type: "Included" or "Excluded" |

2. "Add" the corresponding configuration, "Apply" and finish.

### Add View

|                    |   |                         |
|--------------------|---|-------------------------|
| <b>View</b>        | <input type="text"/>  | Empty value is invalid. |
| <b>OID Subtree</b> | <input type="text"/>  | Empty value is invalid. |
| <b>Type</b>        | <input type="radio"/> Included<br><input checked="" type="radio"/> Excluded |                         |

## 8.3.2 Group Configuration

1. Click the "Device Management > SNMP Configuration > Group Configuration" in the navigation tree as follows.

## Group Table

Showing  entries      Showing 0 to 0 of 0 entries     

| <input type="checkbox"/> | Group | Version | Security Level | View |       |        |
|--------------------------|-------|---------|----------------|------|-------|--------|
|                          |       |         |                | Read | Write | Notify |
| 0 results found.         |       |         |                |      |       |        |

Configure [SNMP View](#) to associate a non-default view with a group.

Interface data are as follows.

| Configuration Items | Description  |
|---------------------|--|
| Group               | Group name   |
| Version             | V1, V2, V3   |
| Security Level      | Security level   |
| View                | Views are divided into view reading, writing and notification. |

2. Click the “Add” to fill in corresponding configuration. “Apply” and finish.

### Add Group

**Group**

**Version**

- SNMPv1
- SNMPv2
- SNMPv3

**Security Level**

- No Security
- Authentication
- Authentication and Privacy

**View**

Read

Write

Notify

## 8.3.3 Group Configuration

1. Click the “Device Management > SNMP Configuration > Group Configuration” in the navigation tree as follows.

### Community Table

Showing  entries      Showing 1 to 1 of 1 entries     

| <input type="checkbox"/> | Community | Group | View | Access    |
|--------------------------|-----------|-------|------|-----------|
| <input type="checkbox"/> | public    |       | all  | Read-Only |

The access right of a community is defined by a group under advanced mode.  
Configure [SNMP Group](#) to associate a group with a community.

Interface data are as follows.

| Configuration Items | Description                        |
|---------------------|------------------------------------|
| Community           | Community configuration            |
| Group               | Group name                         |
| View                | View name                          |
| Access:             | Authority: read only or read-write |

2. “Add” the corresponding configuration. “Apply” and finish.

#### Add Community

**Community**

**Type**  Basic  Advanced

**View**

**Access**  Read-Only  Read-Write

**Group**

### 8.3.4 User Configuration

1. Click the “Device Management > SNMP Configuration > User Configuration” in the navigation tree as follows.

### User Table

Showing All entries      Showing 0 to 0 of 0 entries     

| <input type="checkbox"/> | User | Group | Security Level | Authentication Method | Privacy Method |
|--------------------------|------|-------|----------------|-----------------------|----------------|
| 0 results found.         |      |       |                |                       |                |

Configure [SNMP Group](#) to associate an SNMPv3 group with an SNMPv3 user.

Interface data are as follows.

| Configuration Items | Description         |
|---------------------|---------------------|
| User                | Username            |
| Group               | Group name          |
| Security Level      | Security level      |
| Authentication      | Authentication mode |
| Privacy Password    | Encryption mode     |

2. “Add” the corresponding configuration. “Apply” and finish.

### Add User

**User**

**Group** d

**Security Level**

- No Security
- Authentication
- Authentication and Privacy

**Authentication**

**Method**

- None
- MD5
- SHA

**Password**

**Privacy**

**Method**

- None
- DES

**Password**

## 8.3.5 Engine ID Configuration

1. Click the “Device Management > SNMP Configuration > Engine ID Configuration” in the navigation tree as follows.

2. Click the “User Automation” to fill in corresponding ID value. “Apply” and finish.

### 8.3.6 Trap Configuration

1. Click the “Device Management > SNMP Configuration > Trap Configuration” in the navigation tree as follows.

|                        |  |
|------------------------|--|
| Authentication Failure | <input checked="" type="checkbox"/> Enable |
| Link Up / Down         | <input checked="" type="checkbox"/> Enable |
| Cold Start             | <input checked="" type="checkbox"/> Enable |
| Warm Start             | <input checked="" type="checkbox"/> Enable |

Interface data are as follows.

| Configuration Items | Description          |
|---------------------|----------------------|
| Authen Failure      | Authentication error |
| Link Up/Down        | Port link up/down    |
| Cold start          | Cold start           |
| Warm start          | Warm start           |

2. “Apply” and finish.

## 8.3.7 Notification Configuration

1. Click the “Device Management > SNMP Configuration > Notification Configuration” in the navigation tree as follows.

### Notification Table

Showing  entries      Showing 0 to 0 of 0 entries     

| <input type="checkbox"/> | Server Address | Server Port | Timeout | Retry | Version | Type | Community / User | Security Level |
|--------------------------|----------------|-------------|---------|-------|---------|------|------------------|----------------|
| 0 results found.         |                |             |         |       |         |      |                  |                |

For SNMPv1,2 Notification, [SNMP Community](#) needs to be defined.  
 For SNMPv3 Notification, [SNMP User](#) must be created.

Interface data are as follows.

| Configuration Items | Description  |
|---------------------|--|
| Address Type        | Address type: “Host Name”, “IPv4” or “IPv6”                  |
| Server Address      | Server address info  |
| Version             | SNMP versions: v1, v2 and v3                                 |
| Type                | Notification type: “Trap” or “Inform”                        |
| Community/User      | Community or username  |
| Security Level      | Security level   |
| Server port No.     | 162 by default ranging from 1 to 65,535                      |
| Timeout             | Timeout period: 15s by default ranging from 1 to 300s.       |
| Retry               | The retry interval ranges from 1 to 255s with 3s by default. |

2. “Add” the corresponding configuration. “Apply” and finish.

#### Add Notification

|                         |  |
|-------------------------|--|
| <b>Address Type</b>     | <input checked="" type="radio"/> Hostname<br><input type="radio"/> IPv4<br><input type="radio"/> IPv6                                    |
| <b>Server Address</b>   | <input type="text"/>   |
| <b>Version</b>          | <input checked="" type="radio"/> SNMPv1<br><input type="radio"/> SNMPv2<br><input type="radio"/> SNMPv3                                  |
| <b>Type</b>             | <input checked="" type="radio"/> Trap<br><input type="radio"/> Inform  |
| <b>Community / User</b> | public ▾   |
| <b>Security Level</b>   | <input checked="" type="radio"/> No Security<br><input type="radio"/> Authentication<br><input type="radio"/> Authentication and Privacy |
| <b>Server Port</b>      | <input checked="" type="checkbox"/> Use Default<br><input type="text" value="162"/> (1 - 65535, default 162)                             |
| <b>Timeout</b>          | <input checked="" type="checkbox"/> Use Default<br><input type="text" value="15"/> Sec (1 - 300, default 15)                             |
| <b>Retry</b>            | <input checked="" type="checkbox"/> Use Default<br><input type="text" value="3"/> (1 - 255, default 3)                                   |

## 8.4 RMON Configuration

RMON (Remote Monitoring) is a MIB defined by the IETF (Internet Engineering Task Force) and significantly emphasizes the MIB II standard. It mainly monitors data flow in a network segment or even the whole network, which is one of the widely used network management standards. RMON includes NMS (Network Management Station) and Agent running on various Network devices. RMON Agent running on network monitors or detectors will track and count flow info (e.g. the total number of messages on a network segment during a certain period of time, or that of correct messages sent to a host) on the network segment connected to the port. Based on SNMP architecture, RMON is compatible with the existing SNMP framework. SNMP monitors remote network devices in a more efficient and active manner to supervise subnet operation. RMON can reduce communication flow between NMS and SNMP Agent to manage the large-scale interconnection network conveniently and effectively. Multiple monitors are allowed to collect data by 2 means: The exclusive RMON probe is used to collect data, and the NMS directly manages info and controls network resources. All RMON MIB info can be obtained. RMON Agent with direct access to network devices (router, switch, HUB, etc.) will become the network facility with RMON probe function. RMON NMS exchanges data with SNMP Agent with SNMP basic command to collect network management info. However, limited by device resources, it generally fails to obtain all data of RMON MIB. Most devices collect data from only four groups: alarm, event, history and statistics groups. Area-type switch realizes RMON in the second way. RMON Agent directly accessing switches will become the network facility with RMON probe function. By running the SNMP Agent supported by switches, NMS can obtain overall flow, error statistics, performance statistics and other info on the network segments connected to

ports, so as to manage the network.

## 8.4.1 Port Statistics

The statistics group info reflects the statistics of each monitoring interface on the switch, namely the info accumulated from the beginning of group creation. Statistics include the number of network conflicts, CRC error messages, too-small (too-large) data messages, broadcast/multicast messages, bytes and messages received, etc. With the RMON statistics and management functions, port usage and errors occurred can be monitored and counted respectively.

Instructions

1. Click the “Device Management > RMON Configuration > Message Statistics” in the navigation tree as follows, which reveals the port-related message statistics.

Statistics Table

Refresh Rate: 0 sec

| Entry | Port | Bytes Received | Drop Events | Packets Received | Broadcast Packets | Multicast Packets | CRC & Align Errors | Undersize Packets | Oversize Packets | Fragments | Jabbers | Collisions | Frames of 64 Bytes | Frames of 65 to 127 Bytes | Frames of 128 to 255 Bytes | Frames of 256 to 511 Bytes | Frames of 512 to 1023 Bytes | Frames Greater than 1024 Bytes |   |
|-------|------|----------------|-------------|------------------|-------------------|-------------------|--------------------|-------------------|------------------|-----------|---------|------------|--------------------|---------------------------|----------------------------|----------------------------|-----------------------------|--------------------------------|---|
| 1     | GE1  | 0              | 0           | 0                | 0                 | 0                 | 0                  | 0                 | 0                | 0         | 0       | 0          | 0                  | 0                         | 0                          | 0                          | 0                           | 0                              | 0 |
| 2     | GE2  | 0              | 0           | 0                | 0                 | 0                 | 0                  | 0                 | 0                | 0         | 0       | 0          | 0                  | 0                         | 0                          | 0                          | 0                           | 0                              | 0 |
| 3     | GE3  | 0              | 0           | 0                | 0                 | 0                 | 0                  | 0                 | 0                | 0         | 0       | 0          | 0                  | 0                         | 0                          | 0                          | 0                           | 0                              | 0 |
| 4     | GE4  | 0              | 0           | 0                | 0                 | 0                 | 0                  | 0                 | 0                | 0         | 0       | 0          | 0                  | 0                         | 0                          | 0                          | 0                           | 0                              | 0 |
| 5     | GE5  | 0              | 0           | 0                | 0                 | 0                 | 0                  | 0                 | 0                | 0         | 0       | 0          | 0                  | 0                         | 0                          | 0                          | 0                           | 0                              | 0 |
| 6     | GE6  | 0              | 0           | 0                | 0                 | 0                 | 0                  | 0                 | 0                | 0         | 0       | 0          | 0                  | 0                         | 0                          | 0                          | 0                           | 0                              | 0 |

2. “Clear” and “Refresh” the statistics of the selected port. “View” such statistics as follows.

View Port Statistics

---

Port: GE8

Refresh Rate:  None  5 sec  10 sec  30 sec

Received Bytes (Octets): 0

Drop Events: 0

Received Packets: 0

Broadcast Packets Received: 0

Multicast Packets Received: 0

CRC & Align Errors: 0

Undersize Packets: 0

Oversize Packets: 0

Fragments: 0

Jabbers: 0

Collisions: 0

Frames of 64 Bytes: 0

Frames of 65 to 127 Bytes: 0

Frames of 128 to 255 Bytes: 0

Frames of 256 to 511 Bytes: 0

Frames Greater than 1024 Bytes: 0

Clear Refresh Close

---

3. Select the specified refresh frequency to operate automatically.

## 8.4.2 History Configuration

Once configuring the RMON history group, the switches will periodically collect and temporarily store the network statistics for processing ease, providing historical data on network segment flow, error packets, broadcast packets, bandwidth utilization, and other statistics. Historical data management can be used to set up devices in terms of historical data collection including periodical collection and maintenance of the data of specified ports.

### Instructions

1. Click the “Device Management > RMON Configuration > History Configuration” in the navigation tree as follows.

#### History Table

Showing  entries Showing 0 to 0 of 0 ent

| <input type="checkbox"/>   | Entry | Port                                | Interval | Owner                                 | Sample  |                                     |
|--|-------|-------------------------------------|----------|---------------------------------------|---------|-------------------------------------|
|  |       |                                     |          |                                       | Maximum | Current                             |
| The SNMP service is currently disabled.<br>For RMON configuration to be effective, the <a href="#">SNMP service</a> must be enabled. |       |                                     |          |                                       |         |                                     |
| <input type="button" value="Add"/>   |       | <input type="button" value="Edit"/> |          | <input type="button" value="Delete"/> |         | <input type="button" value="View"/> |

Interface data are as follows.

| Configuration Items | Description  |
|---------------------|--|
| Entry               | Serial No. of event groups   |
| Port                | Ports to be counted  |
| Interval            | Sampling interval ranging from 1 to 3,600 (unit: s), with 1,800s by default. |
| Owner               | Owner  |
| Maximum             | The max number of samples ranges from 0 to 50, with 50 by default.           |
| Current             | Current number of samples  |

3. “Add” corresponding configuration items to configure history group.

### Add History

|            |      |                          |
|------------|------|--------------------------|
| Entry      | 1    |                          |
| Port       | GE1  |                          |
| Max Sample | 50   | (1 - 50, default 50)     |
| Interval   | 1800 | (1 - 3600, default 1800) |
| Owner      |      |                          |

4. “Apply” and finish as follows.

### History Table

Showing  entries Showing 1 to 1 of 1 er

| <input type="checkbox"/> | Entry | Port | Interval | Owner | Sample  |         |
|--------------------------|-------|------|----------|-------|---------|---------|
|                          |       |      |          |       | Maximum | Current |
| <input type="checkbox"/> | 1     | GE1  | 1800     |       | 50      | 50      |

The SNMP service is currently disabled.  
For RMON configuration to be effective, the [SNMP service](#) must be enabled.

## 8.4.3 Event Configuration

Defining event No. and process way, event group is mainly for the events triggered by alarm group configuration items and extended alarm group configuration items. There are several solutions to them: recording in a log table; transmitting a Trap messages to NMS; recording a log and transmitting a Trap message; Don't care.

Instructions

1. Click the “Device Management > RMON Configuration > Event Configuration” in the navigation tree as follows.

### Event Table

Showing All entries      Showing 0 to 0 of 0 entries     

| <input type="checkbox"/> | Entry | Community | Description | Notification | Time | Owner |
|--------------------------|-------|-----------|-------------|--------------|------|-------|
| 0 results found.         |       |           |             |              |      |       |

The SNMP service is currently disabled.  
For RMON configuration to be effective, the [SNMP service](#) must be enabled.

Interface data are as follows.

|                     |                            |
|---------------------|----------------------------|
| Configuration Items | Description                |
| Entry               | Serial No. of event groups |
| Community           | Community name             |
| Description         | Description                |
| Notification        | Notification               |
| Timer               | Time                       |
| Owner               | Owner                      |

2. “Add” corresponding configuration items to configure the event group.

### Add Event

|                     |  |
|---------------------|--|
| <b>Entry</b>        | 1  |
| <b>Notification</b> | <input checked="" type="radio"/> None<br><input type="radio"/> Event Log<br><input type="radio"/> Trap<br><input type="radio"/> Event Log and Trap |
| <b>Community</b>    | <input type="text" value="Default Community"/>   |
| <b>Description</b>  | <input type="text" value="Default Description"/>   |
| <b>Owner</b>        | <input type="text"/>   |

3. “Add” and finish as follows.

### Event Table

Showing  entries      Showing 1 to 1 of 1 entries     

| <input type="checkbox"/> | Entry | Community           | Description         | Notification       | Time | Owner |
|--------------------------|-------|---------------------|---------------------|--------------------|------|-------|
| <input type="checkbox"/> | 1     | Default Description | Default Description | Event Log and Trap |      |       |

The SNMP service is currently disabled.  
For RMON configuration to be effective, the [SNMP service](#) must be enabled.

## 8.4.4 Alarm Configuration

RMON alarm management monitors specific alarm variables, such as port statistics. An alarm event occurs when the value of monitored data exceeds the defined threshold in the corresponding direction, which will be treated according to the prescribed treatment mode. Event definition is realized in event group. System will process as follows after a user defines the alarm entry: The alarm-variable defined by sampling-time should be sampled and the value should be compared with the threshold. For higher threshold, the corresponding event will be triggered.

Click the “Device Management > RMON Configuration > Alarm Configuration” in the navigation tree as follows.

### Alarm Table

Showing  entries      Showing 0 to 0 of 0 entries     

| <input type="checkbox"/> | Entry | Port | Counter |       | Sampling | Interval | Owner | Trigger | Rising    |       | Falling   |       |
|--------------------------|-------|------|---------|-------|----------|----------|-------|---------|-----------|-------|-----------|-------|
|                          |       |      | Name    | Value |          |          |       |         | Threshold | Event | Threshold | Event |
| 0 results found.         |       |      |         |       |          |          |       |         |           |       |           |       |

The SNMP service is currently disabled.  
For RMON configuration to be effective, the [SNMP service](#) must be enabled.

Interface data are as follows.

| Configuration Items | Description  |
|---------------------|--|
| Entry               | Serial No. of alarm groups   |
| Port                | Enter the ports to be counted  |
| Counter             | Sample parameters of alarms  |
| Interval            | Sampling interval ranges from 1 to 2,147,483,647 with the unit of second. 100s by default. |
| Sampling            | Sample types: Absolute and Delete  |

|                     |   |
|---------------------|---|
| Owner               | Owner   |
| Threshold (Rising)  | The threshold of rising edge ranges from 0 to 2,147,483,647.                      |
| Event (Rising)      | Event group index. Corresponding event will be activated when alarm is triggered. |
| Threshold (Falling) | The threshold of falling edge ranges from 0 to 21,474,836,475.                    |
| Event (Falling)     | Event group index. Corresponding event will be activated when alarm is triggered. |

2. “Add” corresponding configuration items to configure the alarm group.

#### Add Alarm

|                 |  |
|-----------------|--|
| <b>Entry</b>    | 1  |
| <b>Port</b>     | GE1  |
| <b>Counter</b>  | Drop Events  |
| <b>Sampling</b> | <input checked="" type="radio"/> Absolute<br><input type="radio"/> Delta   |
| <b>Interval</b> | 100 Sec (1 - 2147483647, default 100)  |
| <b>Owner</b>    |  |
| <b>Trigger</b>  | <input checked="" type="radio"/> Rising<br><input type="radio"/> Falling<br><input type="radio"/> Rising and Falling |

**Rising**

|                  |                                   |
|------------------|-----------------------------------|
| <b>Threshold</b> | 100 (0 - 2147483647, default 100) |
| <b>Event</b>     | 1 - Default Description           |

**Falling**

|                  |                                 |
|------------------|---------------------------------|
| <b>Threshold</b> | 20 (0 - 2147483647, default 20) |
| <b>Event</b>     | 1 - Default Description         |

3. “Apply” and finish as follows.

#### Alarm Table

Showing All entries      Showing 1 to 1 of 1 entries     

|                          | Entry | Port | Counter    |       | Sampling | Interval | Owner | Trigger | Rising    |                     | Falling   |                     |
|--------------------------|-------|------|------------|-------|----------|----------|-------|---------|-----------|---------------------|-----------|---------------------|
|                          |       |      | Name       | Value |          |          |       |         | Threshold | Event               | Threshold | Event               |
| <input type="checkbox"/> | 1     | GE1  | DropEvents | 0     | Absolute | 100      |       | Rising  | 100       | Default Description | 20        | Default Description |

The SNMP service is currently disabled.  
 For RMON configuration to be effective, the [SNMP service](#) must be enabled.

## 8.5 DNS Configuration

DNS is short for Domain Name System to name computers and network services from units to domain hierarchies. A domain name consists of the dots separated by a series of words or abbreviations, each corresponding to a unique IP address. DNS is the server on the Internet that resolves domain names. Applicable to Internet and other TCP/IP networks, DNS name retrieves computers and services through user-friendly names. As one of the core Internet services, DNS is a distributed database that maps domain names and IP addresses mutually.

Instructions:

1. Click on the “Network Configuration > DNS Configuration” in the navigation tree as follows.

### DNS Configuration

### DNS Server Configuration

Interface data are as follows.

| Configuration Items | Description                |
|---------------------|----------------------------|
| DNS State           | DNS switch                 |
| DNS Default Name    | Enter the DNS default name |

2. “Add” to configure DNS server.

### Add DNS Server

3. “Apply” and finish as follows.

### Add DNS Server

|                                      |  |
|--------------------------------------|--|
| IPv4/IPv6 Address                    | <input type="text" value="114.114.114.114"/> |
| <input type="button" value="Apply"/> | <input type="button" value="Close"/>         |

## 8.6 System Time

It is mainly used to configure the system time, and select the time source, daylight-saving time, etc.

Instructions

1. Click on the “Network Configuration > System Time” in the navigation tree as follows.

|                                      |  |                      |       |
|--------------------------------------|--|----------------------|-------|
| <b>Source</b>                        | <input type="radio"/> SNTP<br><input type="radio"/> From Computer<br><input checked="" type="radio"/> Manual Time  |                      |       |
| <b>Time Zone</b>                     | UTC +8:00 ▼  |                      |       |
| <b>SNTP</b>                          |  |                      |       |
| <b>Address Type</b>                  | <input checked="" type="radio"/> Hostname<br><input type="radio"/> IPv4  |                      |       |
| <b>Server Address</b>                | <input type="text"/>   |                      |       |
| <b>Server Port</b>                   | 123 (1 - 65535, default 123)   |                      |       |
| <b>Manual Time</b>                   |  |                      |       |
| <b>Date</b>                          | <input type="text" value="2020-01-01"/>  | YYYY-MM-DD           |       |
| <b>Time</b>                          | <input type="text" value="08:50:59"/>  | HH:MM:SS             |       |
| <b>Daylight Saving Time</b>          |  |                      |       |
| <b>Type</b>                          | <input checked="" type="radio"/> None<br><input type="radio"/> Recurring<br><input type="radio"/> Non-recurring<br><input type="radio"/> USA<br><input type="radio"/> European |                      |       |
| <b>Offset</b>                        | 60 Min (1 - 1440, default 60)  |                      |       |
| <b>Recurring</b>                     | From: Day  | Sun ▼                | Week  |
|                                      | First ▼  | Month                | Jan ▼ |
| <b>Non-recurring</b>                 | From:  | <input type="text"/> | HH:MM |
|                                      | To:  | <input type="text"/> | HH:MM |
| <b>Operational Status</b>            |  |                      |       |
| <b>Current Time</b>                  | 2020-01-01 08:50:59 UTC+8  |                      |       |
| <input type="button" value="Apply"/> |  |                      |       |

Interface data are as follows.

| Configuration Items | Description   |
|---------------------|---|
| Time Source         | Select the time source in SNTP, PC or manual modes  |
| Time Zone           | Set the time zone   |
| Address Type        | Host name or IPv4 address (with time source set by SNTP)  |
| Server Address      | Server Address (with time source set by SNTP)   |
| Server Port No.     | Server Port No. (with time source set by SNTP)  |
| Date                | Date info: dd/mm/yyyy (with time source set in manual mode)                                     |
| Time                | Time info: s/min/hr (with time source set in manual mode)                                       |
| Type                | Daylight-saving time types are divided into None, cyclic, non-cyclic, United States and Europe. |
| Reimbursed Time     | Reimbursed Time of daylight-saving time   |
| Cyclic Mode         | Configure the cyclic mode of daylight-saving time   |
| Non-cyclic Mode     | Configure the non-cyclic mode of daylight-saving time   |

## 9 DHCP

### 9.1 DHCP Server brief introduction

With the expansion of network scale and the improvement of network complexity, network configuration is becoming more and more complex. Computer location changes (such as portable computer or wireless network) and the number of computers exceeds the IP address that can be allocated.

Dynamic Host Configuration Protocol (DHCP) is developed to meet these requirements. The DHCP protocol works in the client / server mode. The DHCP client requests the configuration information from the DHCP server dynamically, and the DHCP server returns the corresponding configuration information according to the policy.

In a typical application of DHCP, it generally includes a DHCP server and multiple clients (such as PC and laptop), as shown in Figure 1-1.

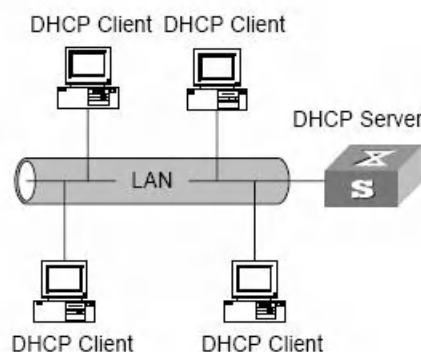

Figure 1-1. In a typical application of DHCP

## 9.2 IP address assignment of DHCP

### 9.2.1 IP address allocation strategy

According to the different needs of clients, DHCP provides three IP address allocation strategies

- Manual address assignment: the administrator binds the fixed IP address for a few specific clients (such as WWW server). Send the configured fixed IP address to the client through DHCP.
- Automatic address assignment: DHCP assigns IP addresses with unlimited lease term to clients.
- Dynamic address assignment: DHCP assigns IP address with valid period to client, and client needs to re-apply for address after expiration of service life. The vast majority of clients get this dynamic address assignment.

### 9.2.2 Dynamic IP address acquisition process

The message interaction process between DHCP client and DHCP server is shown in Figure 1-2.

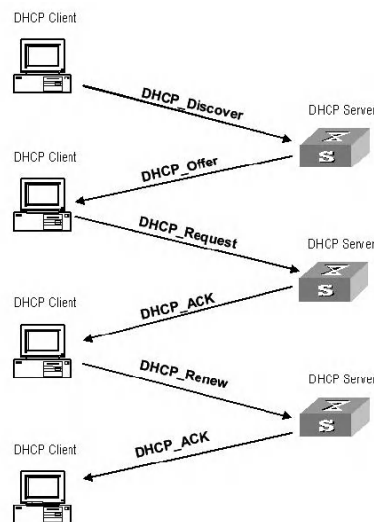

Figure 2-1. Interaction process

In order to obtain the legal dynamic IP address, the DHCP client interacts different

information with the server at different stages. Generally, there are three modes as follows:

(1) DHCP client logs in to the network for the first time

When the DHCP client logs in to the network for the first time, it mainly establishes contact with the DHCP server through four stages

- The discovery phase: the stage in which the DHCP client looks for the DHCP server. The client sends the DHCP discover message in broadcast mode, and only the DHCP server will respond.
- The stage of providing IP address: that is, the stage when the DHCP server provides IP address. After receiving the DHCP discover message from the client, the DHCP server selects an unassigned IP address from the IP address pool and assigns it to the client, and sends the DHCP offer message containing the leased IP address and other settings to the client.
- The selection stage: the stage in which the DHCP client selects the IP address. If more than one DHCP server sends a DHCP offer message to the client, the client only accepts the first received DHCP offer message, and then responds to the DHCP request message by broadcasting to each DHCP server. The information contains the content of requesting IP address from the selected DHCP server.
- The confirmation stage: the stage in which the DHCP server confirms the IP address provided. When the DHCP server receives the DHCP request message answered by the DHCP client, it will send the dhcp-ack confirmation message containing the IP address and other settings provided by the client; otherwise, it will return the dhcp-nak message, indicating that the address cannot be assigned to the client. After receiving the dhcp-ack confirmation message returned by the server, the client will send ARP (the destination address is the address to which it is assigned) in broadcast mode for address detection. If no response is received within the specified time, the client will use this address.

(2) The DHCP client logs on to the network again

When the DHCP client logs in to the network again, it mainly establishes contact with the DHCP server through the following steps.

- After the DHCP client logs in to the network correctly for the first time and then logs in to the network again, it only needs to broadcast the DHCP request message containing the IP address assigned last time, and it is not necessary to send the DHCP discover message again.
- After receiving the DHCP request message, if the address requested by the client is not assigned, the dhcp-ack confirmation message will be returned to notify the DHCP client to continue using the original IP address.
- If the IP address cannot be assigned to the DHCP client (for example, it has been assigned to other clients), the DHCP server will return a dhcp-nak message. After receiving the message, the client sends the DHCP discover message again to request a new IP address.

(3) DHCP client extends lease validity of IP address

The dynamic IP address assigned by the DHCP server to the client usually has a certain lease term. After the expiration, the server will take back the IP address. If the DHCP client

wants to continue using the address, the IP lease needs to be updated.

In practice, the DHCP client sends a DHCP request message to the DHCP server by default when the IP address lease term reaches half to complete the IP lease update. If the IP address is valid, the DHCP server will respond to the dhcp-ack message to inform the DHCP client that a new lease has been obtained.

## 9.3 DHCP global configuration

DHCP global and static binding configuration

1. Click the “DHCP > Property” in the navigation tree as follows.

State  Enable

Static Binding First  Enable

Apply

### DHCP Port Setting Table

Q

| <input type="checkbox"/> | Entry | Port | State    |
|--------------------------|-------|------|----------|
| <input type="checkbox"/> | 1     | GE1  | Enabled  |
| <input type="checkbox"/> | 2     | GE2  | Disabled |
| <input type="checkbox"/> | 3     | GE3  | Disabled |
| <input type="checkbox"/> | 4     | GE4  | Disabled |
| <input type="checkbox"/> | 5     | GE5  | Disabled |
| <input type="checkbox"/> | 6     | GE6  | Disabled |

Port DHCP configuration

1. Click the “DHCP > Property”, and select the port and click “Edit” as follows.

Edit Port Setting

Port GE1-GE2

State  Enable

Apply Close

---

### Notice:

Enable DHCP server or DHCP relay mode, port needs to enable this function

---

## 9.4 IP Pool Setting

DHCP IP pool configuration

1. Click the “DHCP > IP Pool Setting”, Click “Add” to add IP pool as follows.

**IP Pool Table**

Showing  entries      Showing 0 to 0 of 0 entries     

| Pool             | Section |               |             | Gateway | Mask | DNS Primary Server | DNS Second Server | Lease time |
|------------------|---------|---------------|-------------|---------|------|--------------------|-------------------|------------|
|                  | Section | Start Address | End Address |         |      |                    |                   |            |
| 0 results found. |         |               |             |         |      |                    |                   |            |

### IP Pool Table

|                           |   |
|---------------------------|---|
| <b>Pool</b>               | <input type="text"/> (1 to 32 alphanumeric characters)  |
| <b>Gateway</b>            | <input type="text"/>  |
| <b>Mask</b>               | <input type="text"/>  |
| <b>IP Address Section</b> | Section: <input type="text" value="1"/> ▼<br>Start Address: <input type="text"/><br>End Address: <input type="text"/> |
| <b>DNS Primary Server</b> | <input type="checkbox"/> Enable <input type="text"/>  |
| <b>DNS Second Server</b>  | <input type="checkbox"/> Enable <input type="text"/>  |
| <b>Lease time</b>         | <input type="text" value="1"/> Day <input type="text" value="00"/> Hour <input type="text" value="00"/> Minute        |

---

**Notice:**

The start address and end address cannot be configured or contain a gateway address

---

## 9.5 VLAN IF Address Group Setting

Server group configuration

1. Click the “DHCP > VLAN IF Address Group Setting”, enter the DHCP Server Group Table and click “Add” to configure the server group as follows.

### DHCP Server Group Table

Q

| Group ID         | Group IP Address | Bind VLAN Interface |
|------------------|------------------|---------------------|
| 0 results found. |                  |                     |

### DHCP Server Group Table

|                   |                      |
|-------------------|----------------------|
| DHCP Server Group | 1 ▼                  |
| Group IP Address  | <input type="text"/> |

### VLAN interface and server group binding configuration

1. Click the “DHCP > VLAN IF Address Group Setting”, enter the VLAN Interface Address Pool Table, select the interface and server group, and then click “Apply” as follows.

### Vlan Interface Address Pool Table

Interface  ▼

DHCP Server Group  ▼

## 9.6 Client List

### Client list information

1. Click the “DHCP > Client List”, enter DHCP Client list as follows.

**DHCP Client List**

Showing  entries      Showing 0 to 0 of 0 entries     

| <input type="checkbox"/> | MAC Address Table | IPv4 Address | VLAN | Hostname |  |
|--------------------------|-------------------|--------------|------|----------|--|
| 0 results found.         |                   |              |      |          |  |

## 9.7 Client Static Binding Table

Static IP address assignment configuration

1. Click the “DHCP > Client Static Binding Table”, enter Static Binding Table, and click “Add” as follows.

**Static Binding Table**

Showing  entries      Showing 0 to 0 of 0 entries     

| <input type="checkbox"/> | MAC Address Table | IPv4 Address | VLAN | User Name |  |
|--------------------------|-------------------|--------------|------|-----------|--|
| 0 results found.         |                   |              |      |           |  |

---

**Notice:**

The IP configuration of static binding is required to be within the scope of IP address assignment

---

## 10 System Maintenance

### 10.1 Configuration Management

1. Click the “Device Management > Configuration Management > Upgrade/Backups” in the navigation tree as follows.

|                      |   |
|----------------------|---|
| <b>Action</b>        | <input checked="" type="radio"/> Upgrade<br><input type="radio"/> Backup  |
| <b>Method</b>        | <input type="radio"/> TFTP<br><input checked="" type="radio"/> HTTP   |
| <b>Configuration</b> | <input checked="" type="radio"/> Running Configuration<br><input type="radio"/> Startup Configuration<br><input type="radio"/> Backup Configuration<br><input type="radio"/> RAM Log<br><input type="radio"/> Flash Log |
| <b>Filename</b>      | <input type="text"/> <input type="button" value="浏览..."/>   |

2. Instructions for configuration file upgrade: click the “Upgrade” in mode of “TFTP” or “HTTP”, select the corresponding files to be upgraded (servers should be illustrated in TFTP mode). “Apply” and finish as follows.

|                      |   |
|----------------------|---|
| <b>Action</b>        | <input checked="" type="radio"/> Upgrade<br><input type="radio"/> Backup  |
| <b>Method</b>        | <input type="radio"/> TFTP<br><input checked="" type="radio"/> HTTP   |
| <b>Configuration</b> | <input checked="" type="radio"/> Running Configuration<br><input type="radio"/> Startup Configuration<br><input type="radio"/> Backup Configuration<br><input type="radio"/> RAM Log<br><input type="radio"/> Flash Log |
| <b>Filename</b>      | <input type="text"/> <input type="button" value="浏览..."/>   |

3. Instructions for file backup configuration: click the “Backup” in mode of “TFTP” or “HTTP”, select the files or logs to be upgraded (servers should be illustrated in TFTP mode). “Apply” and finish as follows.

|                      |   |
|----------------------|---|
| <b>Action</b>        | <input type="radio"/> Upgrade<br><input checked="" type="radio"/> Backup  |
| <b>Method</b>        | <input type="radio"/> TFTP<br><input checked="" type="radio"/> HTTP   |
| <b>Configuration</b> | <input type="radio"/> Running Configuration<br><input type="radio"/> Startup Configuration<br><input checked="" type="radio"/> Backup Configuration<br><input type="radio"/> RAM Log<br><input type="radio"/> Flash Log |

## 10.2 Configuration Saving

Instructions:

1. Click the “Device Management > Configuration Management > Configuration Saving” in the navigation tree, select the source and target files to be saved, “Apply” and finish. Click the “Factory Reset” as needed as follows:

|                         |   |
|-------------------------|---|
| <b>Source File</b>      | <input checked="" type="radio"/> Running Configuration<br><input type="radio"/> Startup Configuration<br><input type="radio"/> Backup Configuration |
| <b>Destination File</b> | <input checked="" type="radio"/> Startup Configuration<br><input type="radio"/> Backup Configuration  |



Note:

1. Click the “Factory Reset” and “Device Restart” to restore factory settings.
2. Save the “Running Configuration” as the “Start Configuration” (which can be saved as “Backup Configuration” or “Running Configuration”) and the “Backup Configuration” (which can be saved as the “Start Configuration” or “Running Configuration”).
3. Click the “Save” on the upper right to save the running configuration as the start configuration as follows.

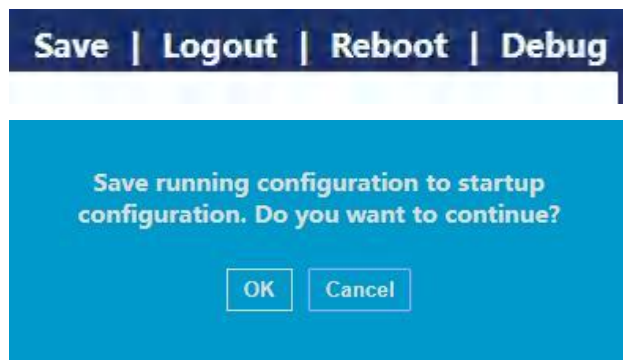

## 10.3 Device Restart

Click the “Reboot” on the upper right as guided as follows.



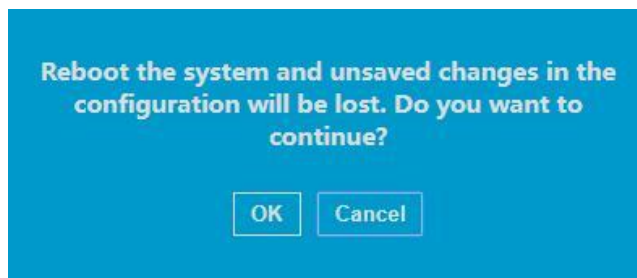

## 10.4 Firmware Management

Instructions:

1. Click the “Device Management > Firmware Management > Upgrade/Backups” in the navigation tree as follows.

Check the “Upgrade” in mode of “TFTP” or “HTTP” and select the system files (xx.bix) to be upgrade. “Apply” and finish as follows.

A configuration form for firmware upgrade. It has four sections: File Type, Action, Method, and Filename. Below the form is an "Apply" button.

|                  |   |
|------------------|---|
| <b>File Type</b> | <input checked="" type="radio"/> Image<br><input type="radio"/> FactoryFile |
| <b>Action</b>    | <input checked="" type="radio"/> Upgrade                                    |
| <b>Method</b>    | <input type="radio"/> TFTP<br><input checked="" type="radio"/> HTTP         |
| <b>Filename</b>  | <input type="button" value="选择文件"/> 未选择任何文件                                 |