

# cudy

## Quick Installation Guide

### Desktop Switch with USB-C Power Input

Model: GS108D | GS108U | GS105D | GS105U | FS108D | FS105D

English	Deutsch	Français	Español
Italiano	Български	Čeština	Dansk
Ελληνικά	Eesti	Suomi	Hrvatski
Magyar	Қазақша	Lietuvių kalba	Latviski
Nederlands	Norsk	Polski	Português
Română	Русский	Slovenčina	Slovenščina
Srpski	Svenska	Türkçe	Україна
العربية	日本語	한국어	Indonesia
ภาษาไทย	Tiếng Việt	中文 (简体)	中文 (繁體)

<b>NEED TECH HELP?</b>	810600663
 www.cudy.com	 support@cudy.com

### English

LED	Description
	Off: Power is off. On: Power is on.
Link/Act (1-5/8)	Off: No link no data. Flash: Link and data. On: Link but no data.

### Deutsch

LED	Beschreibung
	Aus: Strom aus Ein: Strom ein
Link/Akt (1-5/8)	Aus: Kein Link, keine Daten Blinkend: Link und Daten Ein: Link aber keine Daten

### Suomi

LED	Kuvaus
	Pois: Virta pois Päällä: Virta päällä
Yhteys/ Toim(1-5/8)	Pois: Ei linkkiä eikä dataa Vilkkuu: Linkki ja data Päällä: Linkki mutta ei dataa

### Hrvatski

LED	Opis
	Isključeno: Napajanje isključeno Uključeno: Napajanje uključeno
Veza/Aktiv (1-5/8)	Isključeno: Nema veze ni podataka Treperi: Veza i podaci Uključeno: Veza ali nema podataka

### Română

LED	Descriere
	Oprit: Curent oprit Pornit: Curent pornit
Legătură/ Act(1-5/8)	Oprit: Fără link și date Clip: Link și date Pornit: Link dar fără date

### Русский

Индикатор	Описание
	Не горит: нет питания. Горит: есть питание.
Link/Act (порты 1–5/8)	Не горит: нет соединения, данные не передаются. Мигает: есть соединение, данные передаются. Горит: есть соединение, данные не передаются.

### Connection

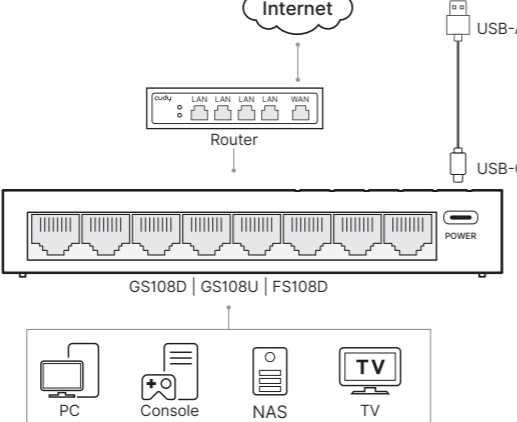

Note: USB-C cable is provided without power adapter.

### Français

LED	Description
	Off: Alimentation éteinte On: Alimentation allumée
Link/Act (1-5/8)	Off: Pas de lien ni données Flash: Lien et données On: Lien mais pas de données

### Español

LED	Descripción
	Off: Sin energía On: Energía encendida
Enlace/Act (1-5/8)	Off: Sin enlace ni datos Flash: Enlace y datos On: Enlace sin datos

### Magyar

LED	Leírás
	Ki: Áram ki Be: Áram be
Kapcs/Akt (1-5/8)	Ki: Nincs link és adat Villog: Link és adat Be: Link de nincs adat

### Қазақша

LED	Сипаттама
	Өшік: Қуат өшік Қосылды: Қуат қосылды
Байланыс/ Әрек(1-5/8)	Өшік: Байланыс жоқ, дерек жоқ Жыпылықтау: Байланыс және дерек Қосылды: Байланыс бар, дерек жоқ

### Slovenčina

LED	Popis
	Vyp: Napájanie vyp Zap: Napájanie zap
Spojenie/ Akt(1-5/8)	Vyp: Žiadny link ani data Blik: Link a data Zap: Link ale žiadne data

### Slovenščina

LED	Opis
	Izklop: Napajanje izklopljeno Vklp: Napajanje vklopljeno
Povezava/ Dej(1-5/8)	Izklop: Brez povezave in podatkov Utripa: Povezava in podatki Vklp: Povezava brez podatkov

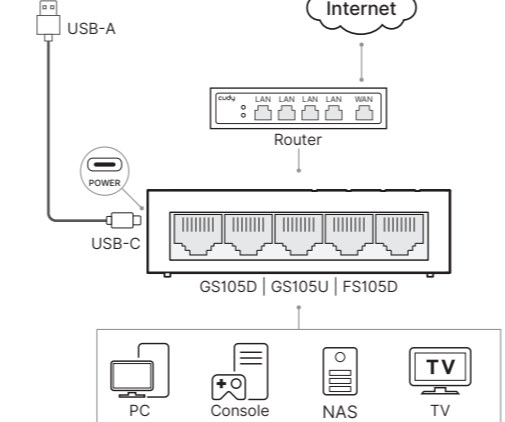

### Italiano

LED	Descrizione
	Off: Alimentazione spenta On: Alimentazione accesa
Collegio/ Att(1-5/8)	Off: Nessun link né dati Flash: Link e dati On: Link ma nessun dato

### Български

LED	Описание
	Изкл: Без захранване Вкл: С захранване
Връзка/ Акт(1-5/8)	Изкл: Няма връзка и данни Мига: Връзка и данни Вкл: Връзка без данни

### Lietuvių kalba

LED	Aprašymas
	Išjungta: Maitinimas išjungtas Jjungta: Maitinimas įjungtas
Ryšys/ Veik(1-5/8)	Išjungta: Nėra ryšio ir duomenų Mirksi: Ryšys ir duomenys Jjungta: Ryšys bet nėra duomenų

### Latviski

LED	Apraksts
	Izslēgts: Strāva izslēgta Ieslēgts: Strāva ieslēgta
Savien./ Darb(1-5/8)	Izslēgts: Nav saites un datu Mirgo: Saite un dati Ieslēgts: Saite bet nav datu

### Srpski

LED	Опис
	Искљ: Струја искљ Укљ: Струја укљ
Веца/Акт (1-5/8)	Искљ: Нема везе ни података Трепери: Веза и подаци Укљ: Веза али нема података

### Svenska

LED	Beskrivning
	Av: Ström av På: Ström på
Länk/Act (1-5/8)	Av: Ingen länk, ingen data Blin: Länk och data På: Länk men ingen data

### Specification

Model	GS108D   GS108U   FS108D	GS105D   GS105U   FS105D
Standards	802.3x Flow Control; 802.3i 10BASE-T; 802.3u 100BASE-TX; 802.3ab 1000BASE-T (except for FS108D and FS105D)	
RJ45 Ports	x 8	x 5
LED	Power; Link/Act	
Dimension	138×61.5×24 mm (5.43×2.42×0.94 inches)	88×52.5×24 mm (3.46×2.07×0.94 inches)
Installation	Desktop; Wall-mount	
Working Temperature	0 °C ~ 40 °C	
Storage Temperature	- 40 °C ~ 70 °C	
Operating Humidity	10% ~ 90% non-condensing	
Storage Humidity	5% ~ 90% non-condensing	

### العربية

LED	Popis
	Vyp: Napájení vypnuto Zap: Napájení zapnuto
Propoj/ Aktiv(1-5/8)	Vyp: Žádný link ani data Bliká: Link a data Zap: Link ale žádná data

### Dansk

LED	Beskrivelse
	Fra: Strøm fra Til: Strøm til
Forb/Akt (1-5/8)	Fra: Ingen link, ingen data Blink: Link og data Til: Link men ingen data

### Ελληνικά

LED	Beschrijving
	Uit: Stroom uit Aan: Stroom aan
Verb/Act (1-5/8)	Uit: Geen link, geen data Knippert: Link en data Aan: Link maar geen data

### Norsk

LED	Beskrivelse
	Av: Strøm av På: Strøm på
Tilkobling/ Act(1-5/8)	Av: Ingen link, ingen data Blink: Link og data På: Link men ingen data

### Türkçe

LED	Açıklama
	Kapalı: Güç kapalı Açık: Güç açık
Bağlantı/ Act(1-5/8)	Kapalı: Bağlantı ve veri yok Yanıp söm: Bağlantı ve veri Açık: Bağlantı var veri yok

### Україна

LED	Опис
	Вимк: Живлення вимк Увімк: Живлення увімк
Зв'язок/ Акт(1-5/8)	Вимк: Нема зв'язку і даних Блима: Зв'язок і дані Увімк: Зв'язок є даних нема

### Ελληνικά

LED	Περιγραφή
	Off: Απενεργοποιημένο On: Ενεργοποιημένο
Σύνδεση/ Ενεργ(1-5/8)	Off: Χωρίς σύνδεση και δεδομένα Flash: Σύνδεση και δεδομένα On: Σύνδεση χωρίς δεδομένα

### Eesti

LED	Kirjeldus
	Väljas: Toide väljas Sees: Toide sees
Ühendus/ Toim(1-5/8)	Väljas: Pole linki ega andmeid Vilgub: Link ja andmed Sees: Link kuid andmeid pole

### Polски

LED	Opis
	Wył: Zasilanie wył Wł: Zasilanie wł
Połączenie/ Act(1-5/8)	Wył: Brak linku i danych Mig: Link i dane Wł: Link ale brak danych

### Português

LED	Descrição
	Desl: Energia desl Lig: Energia lig
Lig/Ativ (1-5/8)	Desl: Sem link nem dados Pisca: Link e dados Lig: Link sem dados

### العربية

LED	الوصف
	إيقاف: طاقة مطفأة تشغيل: طاقة عاملة
رابط/نشط (1-5/8)	إيقاف: لا رابط ولا بيانات وميض: رابط وبيانات تشغيل: رابط لكن لا بيانات

### 日本語

LED	説明
	オフ: 電源オフ オン: 電源オン
リンク/動作 (1-5/8)	オフ: リンクなし データなし 点滅: リンクとデータ オン: リンクあり データなし

